

User Manual

Series 8500 High Speed Packaging Controller Modules



AMCI
Allen-Bradley
SLC 500 I/O
Module

Manual: 940-55020

GENERAL INFORMATION

Important User Information

The products and application data described in this manual are useful in a wide variety of different applications. Therefore, the user and others responsible for applying these products described herein are responsible for determining the acceptability for each application. While efforts have been made to provide accurate information within this manual, AMCI assumes no responsibility for the application or the completeness of the information contained herein.

UNDER NO CIRCUMSTANCES WILL ADVANCED MICRO CONTROLS, INC. BE RESPONSIBLE OR LIABLE FOR ANY DAMAGES OR LOSSES, INCLUDING INDIRECT OR CONSEQUENTIAL DAMAGES OR LOSSES, ARISING FROM THE USE OF ANY INFORMATION CONTAINED WITHIN THIS MANUAL, OR THE USE OF ANY PRODUCTS OR SERVICES REFERENCED HEREIN.

Throughout this manual the following two notices are used to highlight important points.



WARNINGS tell you when people may be hurt or equipment may be damaged if the procedure is not followed properly.



CAUTIONS tell you when equipment may be damaged if the procedure is not followed properly.

No patent liability is assumed by AMCI, with respect to use of information, circuits, equipment, or software described in this manual.

The information contained within this manual is subject to change without notice.

Standard Warranty

ADVANCED MICRO CONTROLS, INC. warrants that all equipment manufactured by it will be free from defects, under normal use, in materials and workmanship for a period of [1] year. Within this warranty period, AMCI shall, at its option, repair or replace, free of charge, any equipment covered by this warranty which is returned, shipping charges prepaid, within one year from date of invoice, and which upon examination proves to be defective in material or workmanship and not caused by accident, misuse, neglect, alteration, improper installation or improper testing.

The provisions of the "STANDARD WARRANTY" are the sole obligations of AMCI and excludes all other warranties expressed or implied. In no event shall AMCI be liable for incidental or consequential damages or for delay in performance of this warranty.

Returns Policy

All equipment being returned to AMCI for repair or replacement, regardless of warranty status, must have a Return Merchandise Authorization number issued by AMCI. Call (860) 585-1254 with the model and serial numbers along with a description of the problem. A "RMA" number will be issued. Equipment must be shipped to AMCI with transportation charges prepaid. Title and risk of loss or damage remains with the customer until shipment is received by AMCI.

24 Hour Technical Support Number

24 Hour technical support is available on this product. For technical support, call (860) 583-7271. Your call will be answered by the factory during regular business hours, Monday through Friday, 8AM - 5PM EST. During non-business hours an automated system will ask you to enter the telephone number you can be reached at. The system will page one of two engineers on call. Have your product model number and a description of the problem ready before you call.

ADVANCED MICRO CONTROLS INC

ABOUT THIS MANUAL

Introduction

This manual explains the operation, installation, and programming of the Series 8500 High Speed Packaging Controllers for Allen-Bradley SLC 500™ systems. It is strongly recommended that you read the following instructions. If there are any unanswered questions after reading this manual, call the factory. An applications engineer will be available to assist you.

AMCI is a registered trademark of Advanced Micro Controls Inc.

The AMCI logo is a trademark of Advanced Micro Controls Inc.

SLC and SLC 500 are trademarks of Allen-Bradley Company.

This product incorporates technology which is licensed by Allen-Bradley Company, Inc. Allen-Bradley has not technically approved, nor does it support this product. All warranty and support for this product and its application is provided solely by Advanced Micro Controls Inc.

Manuals at AMCI are constantly evolving entities. Your questions and comments on this manual and the information it contains are both welcomed and necessary if this manual is to be improved. Please direct all comments to: Technical Documentation, AMCI, 20 Gear Drive, Plymouth Industrial Park, Terryville CT 06786, or fax us at (860) 584-1973.

Revision Record

The following is the revision history for this manual. In addition to the information listed here, revisions will fix any known typographical errors and clarification notes may be added.

This manual, 940-55020, is the first release of the electronic version of this manual. It corresponds to the printed version, numbered 940-05020.

ABOUT THIS MANUAL

Navigating Through This Manual

Bookmarks

The table of contents in the printed version of this manual has been entirely replaced with Acrobat™ bookmarks. To access the bookmarks, press the  button here, or in the toolbar. The bookmarks will appear in a window to the left of the document. The bookmarks are multilevel, just like the table of contents in the printed version. Click on the arrows '▷' next to the bookmarks to expand or contract them. When you see the section you want to go to, click on the bookmark and the manual will jump to the correct page.

Thumbnails

Thumbnails are small images of each page that you can use to navigate between pages. They are not included in this file because they increase the files' size by about 10% and the bookmarks are much more useful.

SERIES 8500 INTRODUCTION

Overview

Until the introduction of the Series 8500 modules, interfacing a high speed programmable limit switch to a SLC 500 programmable controller was a difficult task. Additional I/O wiring, separate panel mounting and displays, and perhaps a custom serial protocol to synchronize the external PLS to the programmable controller was needed to interface the two together. A Series 8500 programmable limit switch module has none of these drawbacks. It plugs directly into the SLC 500 I/O rack and is in constant communication with the processor. Each module accepts a brushless resolver based transducer for position feedback and generates up to 32 limit switch outputs based on the transducers' position and velocity along with your programmed setpoints and speed compensation advances. Each 8500 has several modes of operation that allow you to enable or disable the outputs based on discrete inputs and the speed of the machine.

There are three modules in the 8500 series.

- ▶ **8511** - 16 "Virtual" outputs and 16 "Virtual" inputs
- ▶ **8512** - 16 "Virtual" outputs and inputs and 8 "Real" outputs and inputs
- ▶ **8513** - 16 "Virtual" outputs and inputs and 16 "Real" outputs and inputs

"Real" inputs and outputs are physically connected to an 8500 module. Real Inputs are brought into the module through external boards and are opto-isolated. Real outputs are brought out to external relay boards. These DIN rail mountable boards use fused, plug-in, solid state relays to drive AC or DC loads. Real I/O is updated every 100 or 200 μ Seconds. The actual update time is based on the number of outputs and features used in the module.

"Virtual" inputs and outputs are transmitted over the backplane only. The 8500 modules do not have a direct physical connection to Virtual I/O. Allen-Bradley SLC 500 I/O modules must be used to connect Virtual I/O to the real world. Virtual I/O is stored in the processors' I/O data tables and is automatically updated every scan. Optionally, the 8500 modules can be configured to generate a processor interrupt every time one of the Virtual Outputs changes state. Virtual I/O can be used on machine functions that do not require a 100 to 200 μ Sec update time. By using Virtual Outputs you can significantly reduce processor scan times by off loading the limit switch calculations from the SLC processor to the 8500 module.



Figure 1.1 8500 Module



Overview (continued)

Real I/O is assigned the numbers 1–8 or 1–16. Virtual I/O is assigned the numbers 17–32. These assignments apply to all of the modules in the 8500 Series. Keeping the I/O assignments the same make it easier to upgrade from one module to another with more outputs because the ladder logic stays the same. For example, the ladder logic written for a 8511 module will work without modification on an 8512 or 8513. You need only add logic to program the additional outputs the 8512 or 8513 gives you.

An 8500 has two *modes* of operation, *Group Mode* and *Independent Mode*. When in Group Mode, outputs are combined into groups. The 8500 has a maximum of six groups. Each output group is assigned a *Operating Mode* which controls how the outputs fire. At this time, there are a total of six Operating Modes. These Operating Modes are geared towards high speed packaging and assembly machines. When in Independent Mode, each output is independent of the others and has a corresponding input that can be used to force the output off.

Every 8500 module is programmable from the backplane using a combination of I/O data words and two M files. Because the 8500 uses M files, the SLC processor must be a 5/02 or above and must be installed in a local rack. Fixed SLC systems or 5/01 processors cannot be used with a 8500 module and the 8500 module cannot be installed in a remote rack.

The module is setup by setting its *Programmable Parameters*. The programmable parameters are broken down as follows:

- ▶ **Module Setup Parameters** – Parameters that set the modules' mode of operation, whether or not the module generates a processor interrupt, the active state of the real inputs, and the forced state of the outputs. Parameters that scale the tachometer data and program the setpoints of the two motion detectors are also included in the module setup parameters.
- ▶ **Transducer Setup Parameters** – Parameters that affect the position data.
- ▶ **Limit Switch Parameters** – Parameters that program the type of limit switch, any ANDing with the motion detectors or Enable Input, and setpoint and advance parameters.
- ▶ **Group Setup Parameters** – If you configure the module to operate in Group Mode then you also have Group Setup Parameters. These parameters set the number of limit switch outputs in the group, the Operating Mode of the group, the setpoints of the Group Channel, the Group Offset / Preset value, and the inputs that are used to enable the group outputs.

INTRODUCTION



Module Setup Parameters

Limit Switch Mode

This single bit value sets how the 8500 module will function. The two choices are Group Mode or Independent Mode. The default is Group Mode.

SLC Interrupt

A bit value that configures the module to generate a processor interrupt whenever a Virtual Output changes state. The default value of this bit disables the interrupt. If you use this feature then you must write an interrupt subroutine in your ladder logic. This subroutine runs whenever the 8500 generates an interrupt and must contain an Immediate Input Instruction (IIM) that reads the state of the Virtual Outputs and any logic that acts upon these outputs.



While using the SLC Interrupt will decrease the throughput time of the Virtual Outputs it will increase your overall ladder logic scan time.

Tachometer Response

A bit value that sets how often the 8500 updates the tachometer data to the processor. The two choices are 120 mSec and 504 mSec. The default value is 504 mSec. The 8500 modules have two motion detectors that can be used to disable outputs when the machine speed is outside of the motion detectors programmed range. These motion detectors are also updated at the programmed Tachometer Response. Internally, the tachometer is updated every 24 mSec. This update time is used when calculating the limit output advance values.

Tachometer Scalars

The 8500 allows you to scale the tachometer value reported to the processor. Therefore you can have the 8500 report a tachometer value scaled to boxes per minute, inches per minute, or any other meaningful value instead of revolutions per minute. The tachometer is scaled with three values, *Tach Multiplier*, *Tach Divisor*, and *Tach Decimal Point*. The tachometer reports the rounded off integer value of the equation: $((\text{Speed}[\text{RPM}] * \text{Tach Multiplier}) / \text{Tach Divisor}) / \text{Tach Decimal Point}$. The Tach Multiplier can be any integer between 0 and 1,100. The Tach Divisor can be any integer between 1 and 63. The Tach Decimal Point can be 1, 10, 100, or 1000. As an example, assume a speed of 100 RPM, a multiplier of 2, a divisor of 3. The table below shows the different Tachometer values based on the Tach Decimal Point value.

	DECIMAL POINT VALUE			
	1	10	100	1000
Calculated Tach	66.67	6.67	0.67	0.067
Reported Tach	67	7	1	0

Table 1.1 Effect of Tachometer Scalars

When programming the Tach Decimal Point, you enter 0, 1, 2, or 3 into your programming data. This corresponds to a Tach Decimal Point Value of 1, 10, 100 or 1000.



Module Setup Parameters (continued)

Real Input Active State

These sixteen bit values program the active state of the Real Inputs. When an Active State bit is set to its default value of zero, the corresponding input works like a normally closed relay. The input must have current flowing through it to be deactivated. When an Active State bit is set to one, the corresponding input works like a normally open contact. The input must have current flowing through it to be activated.

Input Forces

You can force any Real Input on or off by setting the appropriate bit in the output image table. A Force OFF bit takes precedence over the corresponding Force ON bit. Virtual Inputs cannot be forced in this manner. You must force Virtual Inputs on or off with ladder logic.

Output Forces

You can force any output on or off by setting the appropriate bit in the output image table. A Force OFF bit takes precedence over the corresponding Force ON bit.

Motion Detector ON/OFF setpoints

The 8500 has two motion detectors, *MD1* and *MD2*, that function as speed based limit switches. You program a low speed setpoint and a high speed setpoint for each motion detector. If the low speed setpoint is less than the high speed setpoint then the output will be on when the velocity is between the two setpoints and off at all other speeds. If the low speed setpoint is greater than the high speed setpoint then the output will be off when the velocity is between the two setpoints and on at all other speeds. You can logically AND any limit switch output with the state of either motion detector. This disables the limit switch output unless the machine is running within the programmed range. The motion detector setpoints are always programmed in RPM, regardless of the values of the Tachometer Scalars. The setpoints have a range of zero to 32,767 RPM.

How often the ON/OFF state of the motion detectors updates is based on the Tachometer Response. Like the tachometer, they will update either every 120 mSec or 504 mSec.



If you are using the motion detectors to disable limit switch outputs and your machine accelerates to its final speed quickly, you may have to change the Tachometer Response from its default of 504 mSec to 120 mSec. This insures that the limit switches will be enabled as quickly as possible once the machine is running at operating speed.

INTRODUCTION



Transducer Setup Parameters

Count Direction

A bit value that sets the direction the transducer shaft must rotate to increment the position count. It can be set to clockwise or counter-clockwise. It defaults to clockwise. Note that it is also possible to reverse the count direction by switching one of the pairs in the transducer cable.

Scale Factor

Sets the position resolution of the 8500 module. It is programmable to any value between 2 and 1,024 counts per turn. The Scale Factor defaults to 1,024 counts per turn.

Preset Value

This parameter sets the value that the *Machine Position* will be set to when it is preset from the backplane. Its default is zero and is programmable to any value between zero and (Scale Factor - 1).

The *Machine Position* is the position that the 8500 reports back to the processor. As you will see later, when operating the 8500 in Group Mode, you can offset the position that the *group* uses when determining the on/off state of its outputs. When this happens, the manual will use the term *Group Position* to distinguish this position count from the Machine Position.

Machine Offset

This number is added to the absolute resolver position to calculate the Machine Position. Its default value is zero and can be programmed to any value between 0 and (Scale Factor - 1). The Machine Offset gives you the ability to set the Machine Position to any value without rotating the transducer shaft.

Presetting the position forces the module to recalculate the Machine Offset.

The 8500 does not store the Machine Offset in non-volatile memory but does make it available to the processor as a data word in an M file. In order to keep the Machine Position an absolute value, you must store the Machine Offset in an integer file and write it down to the 8500 every time you configure the module.



Limit Switch Parameters

Limit Switch Type Parameter

Programs the type of limit switch the output channel will be. The three choices are *Normal*, *Pulse*, and *Timed*. Normal outputs turn on and off based on position. Pulse outputs generate a pulse train between two position values. Timed outputs are position on, time off outputs.

Motion ANDing Parameter

You can disable a limit switch output by ANDing it with one of the two motion detectors. This prevents the output from firing until the machine is running within the range programmed into the motion detector. This parameter give you the choice of not ANDing the output with a motion detector or ANDing it with MD1 or MD2.

Enable ANDing Parameter

When in Group Mode you can disable a limit switch output by ANDing it with an input. Use this bit value to attach the *LS Enable Input* to the limit switch output. This parameter is not used when in Independent Mode because each output has a corresponding, dedicated input that can be used to disable the output.

Limit Switch ON / OFF Setpoints

Limit Switch Setpoints are a pair of values which are the positions that the output turns on and off at. The limit switch is on when the position value is between the two setpoints. Setpoints can be programmed to any value between 0 and (Scale Factor -1).

Normal Limit Switch – Eight pairs of ON / OFF setpoints that give you the ability to turn the output on and off eight times per cycle.

Pulse Limit Switch – One ON / OFF setpoint pair that sets the leading edge of the pulse train and the trailing edge of the pulse train. Two additional parameters, *Pulse Quantity* and *Pulse On Count*, must also be programmed. Pulse Quantity is the number of pulses in the train. Pulse On Count is the number of counts each pulse is on. The difference between the ON and OFF setpoints must be greater than or equal to: $((\text{Pulse Qty} * \text{On Count}) + (\text{Pulse Qty} - 1))$.

Timed Limit Switch – One ON / OFF setpoint pair that sets the ON position and OFF position of the limit. A third parameter sets the amount of time the output is on. Usually, the output will turn on at the ON setpoint and remain on for the specified length of time. However, if the OFF setpoint is reached before the output times out, the output turns off immediately. The maximum length of time an output can be on is 9.999 seconds. You can have a maximum of four Real and four Virtual Outputs programmed to be Timed limit switches

Limit Switch ON / OFF Advances

Two parameters that allow the limit switch channel to compensate for fixed delays in the system. The maximum compensation is ± 99.9 mSec. Setting the Advance to a positive value will force the output to turn on earlier in the cycle. Setting the Advance to a negative value will force the output to turn on later in the cycle.

INTRODUCTION



Group Setup Parameters

If you are using the 8500 module in Group Mode the Group Setup Parameters are also available. There is a maximum of six groups available.

Group Type

Sets the type of inputs and outputs, either Virtual or Real, associated with the group. You cannot associate both types of I/O with a single group. Therefore you can have a maximum of sixteen outputs in a single group. If you are using a 8512 you can have a maximum of eight real outputs assigned to a single group.

Output Quantity

This parameter sets the number of limit switch outputs in the group. Outputs are assigned to a group in consecutive order. As an example, assume a 8513 with Group 1 assigned six real outputs and Group 2 assigned eight real outputs. The limit switch outputs 1 – 6 are assigned to Group 1 and outputs 7 – 14 are assigned to Group 2. This leaves a total of two real outputs for another group. If you try to assign more than two real outputs to another group the 8513 will respond with an error message.

Operating Mode

This parameter specifies the groups' Operating Mode. Six different modes are presently available. A detailed description of the different Operating Modes is given in chapter 2.

First Cycle Input Type

This bit value sets the type of input, either Real or Virtual, that is used as the groups' *First Cycle Input*. The input is only available if the Group is configured to use Operating Mode 5. It allows you to fire the outputs on the first machine cycle. Note that you can assign the virtual First Cycle Input to a group controlling real outputs or the real First Cycle Input to a group controlling virtual outputs. If your group is not using Mode 5 then set this parameter to its default value of zero, which selects the physical input.

Group Channel ON / OFF Setpoints

Each Group has an internal limit switch called the Group Channel. Its use is dependent on the groups' Operating Mode. It is typically used either to enable or disable the group outputs. The state of the Group Channel is only used internally by the group. It not made available as a real or virtual output.

Group Offset / Preset Value

Each group has an offset / preset value to adjust the machine position for the group. In Operating Modes 0, 3, 4 and 5 this value acts as a position offset. In Operating Modes 1 and 2 this value acts as a preset. These values do not affect the Machine Offset that adjusts the position value reported over the backplane. They only affect the position value used by the group when calculating the on/off status of the groups' limit switch outputs.



INTRODUCTION

Notes



INDEPENDENT OPERATING MODE

This chapter contains information applicable to the 8500 when it is in Independent Mode. If you are using the 8500 in Group Mode you can ignore the information in this chapter.

When To Use Independent Mode

You should use Independent Mode when your only requirement is for position based limit switches. Group Mode adds powerful functionality to the 8500 that can decrease PLC scan times by off loading a substantial amount of logic from the processor. However, if you do not need this functionality, operating the 8500 in Independent Mode eliminates all of the Group Mode programming which simplifies module setup. When in Independent Mode, the Enable ANDing Parameter and all of the Group Setup Parameters are not used.

Independent Mode Features

The following limit switch features are still available while in Independent Mode.

Limit Switch Output Type

You can program the type of limit switch the output channel will be, Normal, Pulse, or Timed. Normal outputs turn on and off based on position. Pulse outputs generate a pulse train between two position values. Timed outputs are position on, time off outputs. The maximum number of timed outputs you can have is four Real and four Virtual. Therefore, you have a maximum of four timed outputs on the 8511 and eight timed outputs on the 8512 and 8513.

Speed Compensation

Separate ON/OFF advances for each limit switch are still available to compensate for fixed delays in the system. The maximum compensation is ± 99.9 mSec. Setting the Advance to a positive value will force the output to turn on earlier in the cycle. Setting the Advance to a negative value will force the output to turn on later in the cycle.

Motion ANDing

Both motion detectors are available in Independent Mode. You can disable a limit switch output by ANDing it with either of the two motion detectors. This prevents the output from firing until the machine is running within the range programmed into the motion detector.



INDEPENDENT MODE

Independent Mode Features (continued)

Real LS Disable Inputs

A feature not available in Group Mode is the Real LS Disable Inputs. While in Independent Mode, each Real output of the 8512 and 8513 can be disabled by the corresponding Real input. Output 1 is attached to Input 1, Output 2 to Input 2, etc. The Real outputs will not fire unless the corresponding Real input is active. When in Group Mode, there is a single input that can be used to disable outputs.

Virtual Outputs do not have Disable Inputs. You can use the Output Force OFF bits instead.

By default, this feature is automatically disabled. If you leave the Real Input Active State parameters to their default values of zero, the inputs act like normally closed relays. If you do not use the input, the outputs will then fire normally.

GROUP OPERATING MODES

This chapter contains information applicable to the 8500 when it is in Group Mode. It gives detailed descriptions of the six group Operating Modes. If you are using the 8500 in Independent Mode you can ignore the information in this chapter.

Assigning Limit Outputs to Groups

Each Group has an *Output Quantity* parameter. This parameter defines the number of outputs assigned to the group. Outputs are assigned in consecutive order. Because Real and Virtual outputs cannot be assigned to the same group, the maximum number of outputs per group is sixteen. When operating the 8500 in Group Mode you must assign an output to a group before using it. The module will give you an error if you try to program Limit Switch Parameters for a limit switch output that is not assigned to a group.

Group Inputs

Each of the six groups has two dedicated inputs but the group uses only one of the two. One of these *Group Inputs* is Real and the other is Virtual. The type of input used is the same as the type of outputs assigned to the group. If the group controls real outputs, then the real Group Input is used. If the group controls virtual outputs, then the virtual Group Input is used. The Operating Mode assigned to the group defines the function of the input.

When the 8500 is in Group Mode there are four additional inputs. The first two are the *LS Enable Inputs*. Like the Groups Inputs, there is one real LS Enable Input and one virtual LS Enable Input. Any real output can be tied to the real LS Enable Input. Likewise, any virtual output can be tied to the virtual LS Enable Input. The output is tied to the LS Enable Input with the ANDing function. That is to say, every output tied to the corresponding LS Enable Input will not fire if the LS Enable Input is not active.

The second two additional inputs are the *First Cycle Inputs*. Like the other inputs, there is one real First Cycle Input and one virtual First Cycle Input. These inputs only apply to the groups operating in Mode 5. The purpose of the First Cycle Inputs is to enable the group outputs to fire on the first machine cycle if other conditions are also met. Its use is fully described below in the Mode 5 section of this chapter.

NOTE Unlike the Group and LS Enable Inputs you can assign either First Cycle Input to any group operating in Mode 5. This gives you the ability to enable a group of real outputs to fire with a virtual input from the backplane.



GROUP MODES

Group Inputs (continued)

The table below lists the input numbers for the Group, LS Enable, and First Cycle Inputs.

	Real Input	Virtual Input
Group 1 Input	1	17
Group 2 Input	2	18
Group 3 Input	3	19
Group 4 Input	4	20
Group 5 Input	5	21
Group 6 Input	6	22
LS Enable Input	7	23
First Cycle Input	8	24

Table 3.1 Group Mode Inputs

Mode 0

When a group is placed in Mode 0 its outputs will function as normal limit switches. Inputs assigned to the group are not used and the Group Channel need not be programmed. Outputs in the group can still be conditioned by tying them to the LS Enable Input and/or either of the two motion detectors. The outputs assigned to the group will cycle their outputs once per transducer rotation.

The group has a Group Offset that can be used to offset the Group Position from the Machine Position. If the Group Offset equals zero then the Group Position will equal the Machine Position.

GROUP MODES



Mode 1

When a group is placed in Mode 1 its outputs will function as normal limit switches. Outputs in the group can be conditioned by tying them to the LS Enable Input and/or either of the two motion detectors. The difference between Mode 1 and Mode 0 is that you can use the Group Input to preset the Group Position. Typically the Group Input is tied to a sensor that detects a registration mark on the machine or product. When the mark is sensed the Group Position is preset to the value programmed in the Group Preset parameter. This synchronizes the outputs in the group to the registration mark. The timing diagram below shows how the Group Input and Group Channel are used. It shows the Group Position being preset to zero. However, it can be preset to any value between zero and (Scale Factor -1).

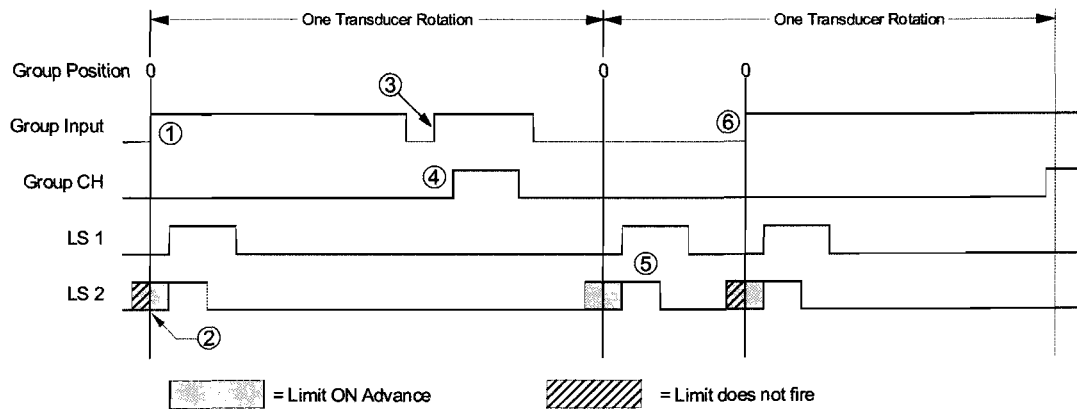

Figure 3.1 Mode 1 Timing Diagram

- ① When the Group Input makes a positive transition, (inactive state to active state), the Group Position is set equal to the value of the Group Preset parameter. Once the position is preset, the Group Input is ignored until the Group Channel becomes active.
- ② Limit Switch 2 turns on immediately because of its advance. Note that LS 2 cannot fire correctly at this speed when the position is preset because of its advance.
- ③ This edge on the Group Input is ignored because the Group Channel dwell has not been reached.
- ④ The Group Input is enabled once the Group Channel dwell is reached. The next positive edge on the Group Input will preset the Group Position.
- ⑤ Outputs continue to cycle at a rate of once per transducer rotation.
- ⑥ This Group Input transition presets the Group Position and the cycle starts again.

You can preset the Group position multiple times per transducer rotation by programming the Group Channel appropriately.





Mode 2

Mode 2 is very similar in operation to Mode 1. The only difference between the two Operating Modes is that the outputs in Mode 2 are normally disabled. The Group Input is used to preset the Group Position to the value of the Group Preset parameter. When the Group Position is preset, the outputs are enabled until the dwell in the Group Channel is reached. Outputs in the group can be further conditioned by tying them to the LS Enable Input and/or either of the two motion detectors. Typically, the Group Input is tied to a sensor that detects the presence of product. When the product is sensed, the group outputs are synchronized to the product and are allowed to fire. If a product is not present on the next transducer rotation, the outputs will not fire again. The timing diagram below shows how the Group Input and Group Channel are used. It shows the Group Position being preset to zero. However, it can be preset to any value between zero and (Scale Factor -1).

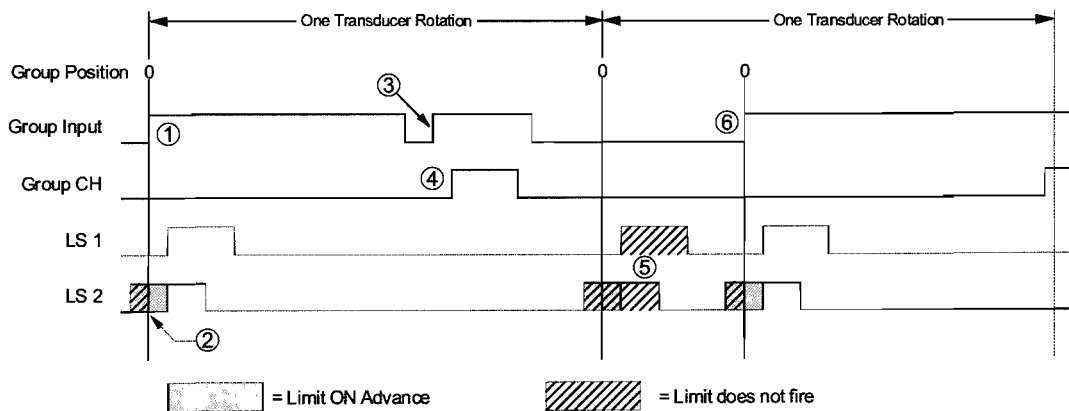

Figure 3.2 Mode 2 Timing Diagram

- ① When the Group Input makes a positive transition, (inactive state to active state), the Group Position is set equal to the value of the Group Preset parameter. Once the position is preset, the Group Input is ignored until the Group Channel dwell is reached.
- ② Limit Switch 2 turns on immediately because of its advance. Note that LS 2 cannot fire correctly at this speed because of its advance.
- ③ This edge on the Group Input is ignored because the Group Channel dwell has not been reached.
- ④ The Group Input is enabled and the group outputs are disabled once the Group Channel dwell is reached. The next positive edge on the Group Input will preset the Group Position.
- ⑤ Outputs do not cycle because they have been disabled by the Group Channel dwell.
- ⑥ This Group Input transition presets the Group Position and the cycle starts again.



You can preset the Group position multiple times per transducer rotation by programming the Group Channel appropriately.

GROUP MODES



Mode 3

When a group is placed in Mode 3 the Group Input is used to enable the outputs in the group. The Group Channel has no effect and need not be programmed. The Group Input is typically tied to a sensor that detects the presence of material. The outputs will then only fire when material is present. Outputs in the group can be further conditioned by tying them to the LS Enable Input and/or either of the two motion detectors. The outputs assigned to the group will cycle their outputs once per transducer rotation.

The group has a Group Offset that can be used to offset the Group Position from the Machine Position. If the Group Offset equals zero then the Group Position will equal the Machine Position.

The timing diagram below shows how the Group Input effects the outputs in the group.

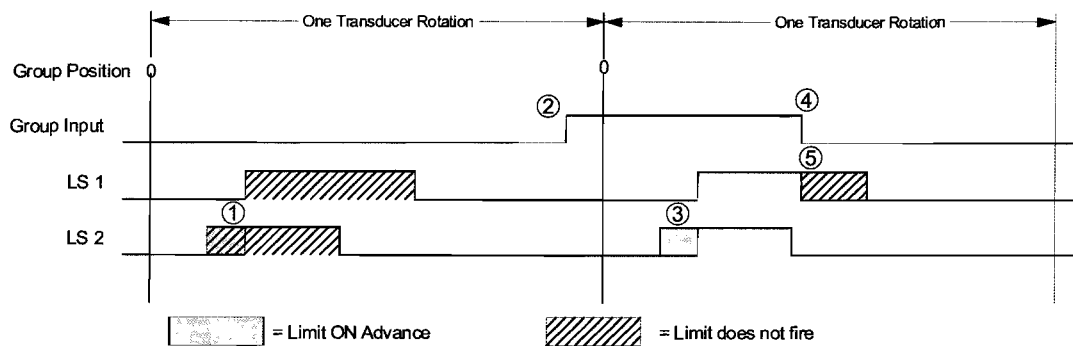

Figure 3.3 Mode 3 Timing Diagram

- ① Outputs do not fire because the Group Input is not active.
- ② The Group Input detects the presence of material.
- ③ The outputs begin to cycle.
- ④ A break in the material occurs and the Group Input turns off.
- ⑤ The outputs are disabled within 1 mSec of the Group Input transition.



Mode 4

When a group is placed in Mode 4 the Group Input is used to enable the outputs for one cycle. The positive transition, (inactive state to active), on the Group Input must occur during the dwell programmed into the Group Channel in order for the outputs to be enabled. The outputs are enabled until the dwell on the Group Channel is again reached. The Group Input is typically tied to a sensor that detects the presence of material. The outputs will then only fire when material is present and correctly positioned. Outputs in the group can be further conditioned by tying them to the LS Enable Input and/or either of the two motion detectors. The outputs assigned to the group will cycle their outputs once per transducer rotation.

The group has a Group Offset that can be used to offset the Group Position from the Machine Position. If the Group Offset equals zero then the Group Position will equal the Machine Position.

The timing diagram below shows how the Group Input effects the outputs in the group.

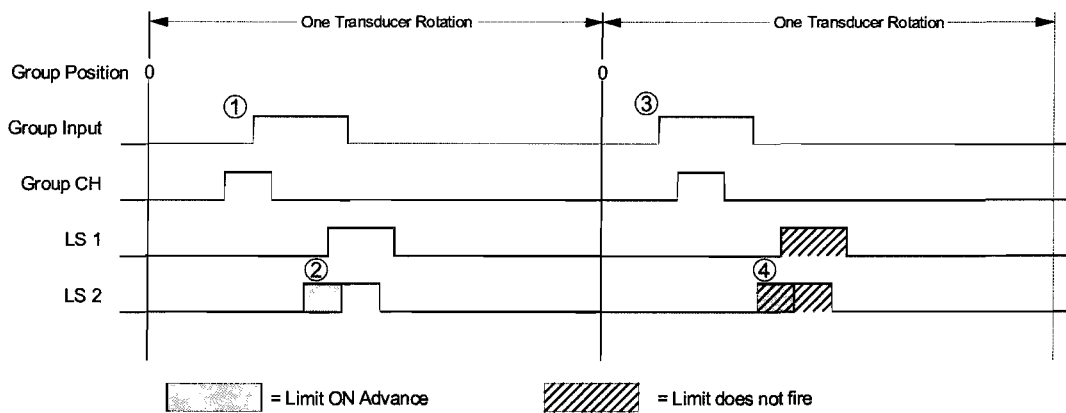

Figure 3.4 Mode 4 timing Diagram

- ① A positive transition on the Group Input occurs during the Group Channel dwell.
- ② The outputs are enabled for this one cycle. The outputs are disabled by the positive transition on the Group Channel in the next turn.
- ③ A positive transition on the Group Input occurs before the dwell on the Group Channel.
- ④ The outputs are disabled for this cycle because a positive transition on the Group Input did not occur during the Group Channel dwell.



Mode 5

When a group is placed in Mode 5 the Group Input is used to enable the outputs for one cycle. In Mode 4, a positive transition on the Group Input must occur during the Group Channels' dwell in order for the outputs to be enabled. In Mode 5, the outputs are enabled if the Group Input is active at any time in the Group Channels' dwell. The outputs are enabled for one cycle.

The Group Input is typically tied to a sensor that detects the presence of material. The outputs will then only fire when material is present. Outputs in the group can be further conditioned by tying them to the LS Enable Input and/or either of the two motion detectors.

The outputs are disabled within the programmed update time of the Tach Response if the machine stops for any reason. In gluing applications this shuts off the glue gun if the machine stops while glue is being applied. The First Cycle Input can be used to re-enable the outputs once the machine has started again.

The group has a Group Offset that can be used to offset the Group Position from the Machine Position. If the Group Offset equals zero then the Group Position will equal the Machine Position.

The timing diagram below shows how the Group Input effects the outputs in the group.

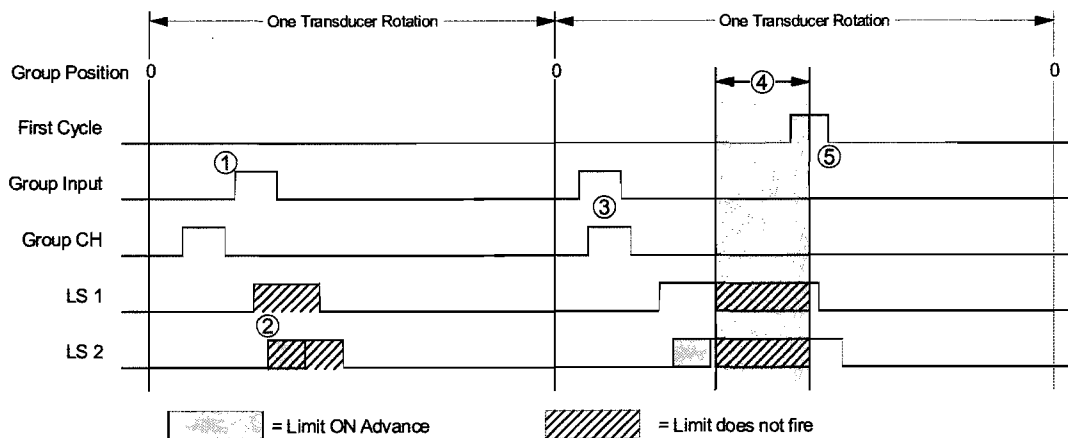

Figure 3.5 Mode 5 Timing Diagram

- ① The Group Input is not active during the Group Channel dwell.
- ② Outputs are disabled for this cycle because the input was not active.
- ③ The Group Input is active during at least part of the Group Channel dwell. This enables the outputs for this cycle.
- ④ The machine is stopped. The outputs are disabled within the programmed update time of the Tach Response.
- ⑤ The First Cycle input is activated when the machine is started. This re-enables the outputs and they fire for the rest of the cycle.



If the First Cycle input is not activated before the machine is restarted, the outputs will remain disabled until the Group Input is active during the Group Channel dwell.



Notes

INSTALLATION

This chapter describes how to install a Series 8500 system. It covers module, transducer, and relay board installation and the cabling needed to connect the components together.

Power Requirements

A 8500 module draws its power from the I/O rack +5Vdc supply. The maximum current draw is 0.450 amps. Therefore, the maximum power draw is 2.25 watts. Add this to the power requirements of all the other modules in the rack when sizing the power supply.

Installing the Module



WARNING

Remove system power before removing or installing any module in an I/O rack. Failure to observe this warning may result in damage to the module's circuitry and/or undesired operation with possible injury to personal.

Because the 8500's use M files, you cannot install the 8500 module in a remote I/O rack. You can install the module in any free slot of local racks except for the processor slot of an expanded local rack.

- 1) Align the modules' right circuit board with the top and bottom card guides in the rack.
- 2) Gently slide the module into the rack until the top and bottom latches secure the module in place.
- 3) To remove the module, depress the top and bottom latches and slide the module out of the rack.

Figure 4.1 shows the placement of the Relay Board I/O and Transducer Input Connectors on the 8500.

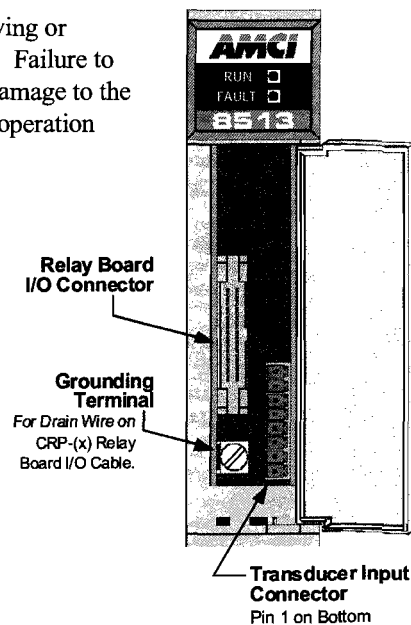

Figure 4.1 8500 Connectors

Status LEDs

Two LEDs on the front panel shows the operating status of the module.

RUN – This green LED is on when the module is operational.

FAULT – This LED is on when there is a transducer fault. It blinks when a working transducer is attached to the module but the transducer fault has not been cleared.

Module ID Code

All 8500's have an ID Code of 9935. This reserves 8 Input and 8 Output words for the module. When configuring the slot you must also enter the 'SPIO CONFIG' menu and specify a M0 File size of 120 words and a M1 File size fo 650 words. If you do not configure the M files correctly you will get an error message when you switch the processor to Run Mode. The error message is "M1/M0 File Configuration Error, slot X" were "X" is the slot the 8500 plugs into.

Transducer Specifications

HT Transducers		H25 Transducers	
Shaft Diameter 0.625"		Shaft Diameter 0.375"	
Shaft Loading Radial: 400 lbs. max. Axial: 200 lbs. max.		Shaft Loading Radial: 40 lbs. max. Axial: 20 lbs. max.	
Starting Torque 8 oz.in. @ 25° C		Starting Torque 1.5 oz.in. @ 25° C	
Moment of Inertia 20 oz-in-sec ²		Moment of Inertia ... 4 oz-in-sec ²	
Weight 4 lbs.		Weight 1 lbs.	
Enclosure NEMA 13 or 4X		Enclosure NEMA 4	
Environmental (All Transducers)			
Operating Temp -20 to 125°C		Shock 50G's for 11 mSec	Vibration 5 to 2000 Hz @ 20 G's

Table 4.1 Transducer Specifications

Transducer Mounting

All AMCI resolver based transducers are designed to operate in the industrial environment and therefore require little attention. However, there are some general guidelines that should be observed to ensure long life.

Limit transducer shaft loading to the following maximums:

	Radial Load	Axial Load
All HT-20 Transducers	100 lbs. (445 N)	50 lbs. (222.4 N)
All H25 Transducers	30 lbs. (133 N)	15 lbs. (66.7 N)

Table 4.2 Transducer Bearing Loads

Minimize shaft misalignment when direct coupling shafts. Even small misalignments produce large loading effects on front bearings. It is recommended that you use a flexible coupler whenever possible.



The transducer housing must be connected to Earth Ground. This is usually accomplished through its mounting. If not properly grounded through its mounting, run a heavy guage wire from the transducer housing to an Earth Ground point as close as possible to the transducer.

INSTALLATION



Transducer Outline Drawings

HT-20: Anodized Aluminum Body, Steel Shaft, NEMA 13

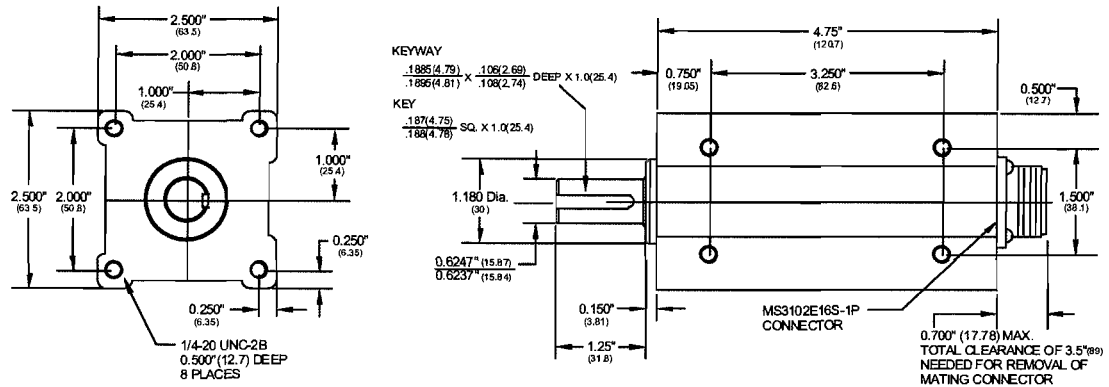

Figure 4.1 HT-20 Outline Drawing

HT-20S: Anodized Aluminum Body, Steel Shaft, NEMA 13

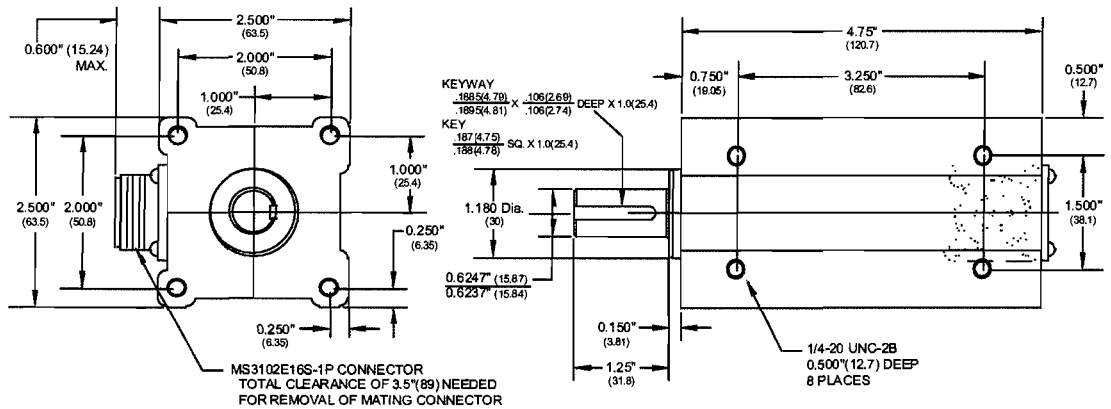

Figure 4.2 HT-20S Outline Drawing



INSTALLATION

Transducer Outline Drawings (continued)

HT-20K: Hard Coat Anodized Aluminum Body, Stainless Steel Shaft, NEMA 4X

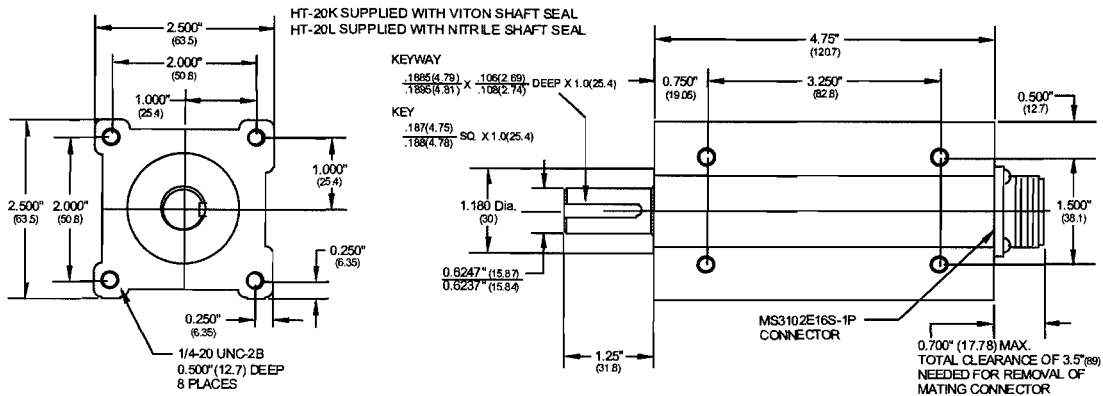

Figure 4.3 HT-20K Outline Drawing

HT-20C: Stainless Steel Body & Shaft, NEMA 4X

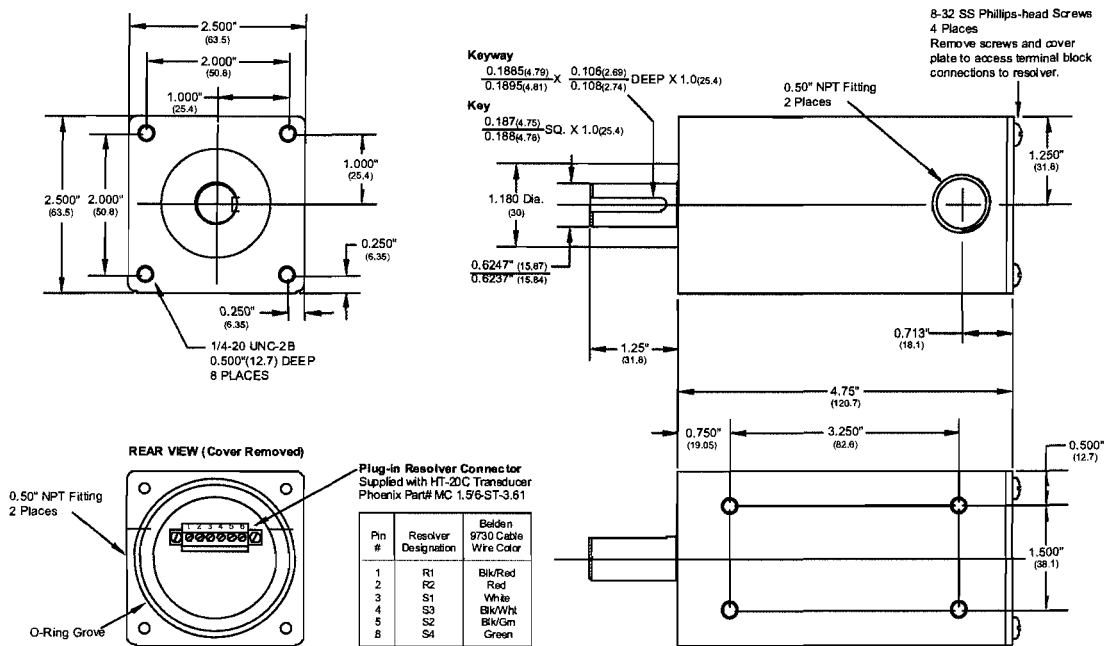

Figure 4.4 HT-20C Outline Drawing

INSTALLATION



Transducer Outline Drawings (continued)

H25FE & H25SE: Anodized Aluminum Body, Steel Shaft, NEMA 4

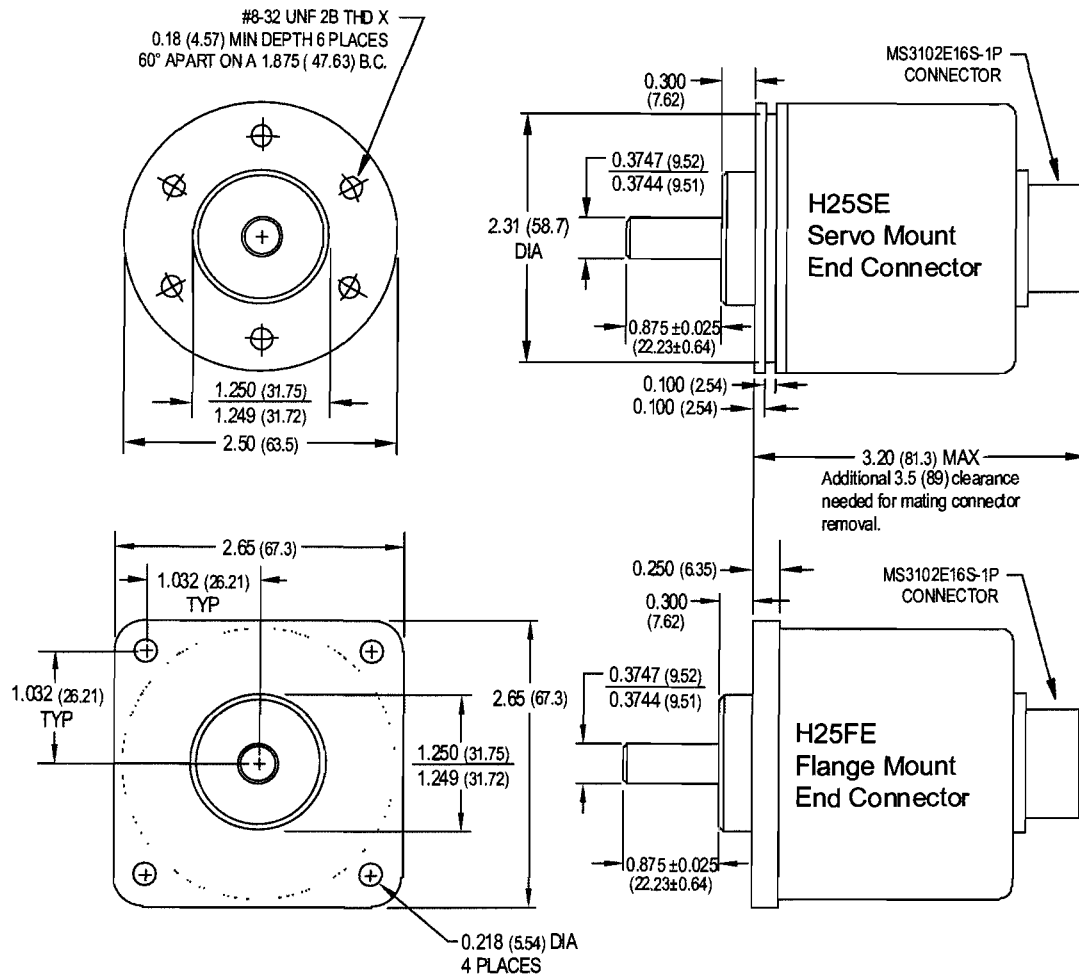

Figure 4.5 H25FE and H25SE Outline Drawing



INSTALLATION

Transducer Outline Drawings (continued)

H25FS & H25SS: Anodized Aluminum Body, Steel Shaft, NEMA 4

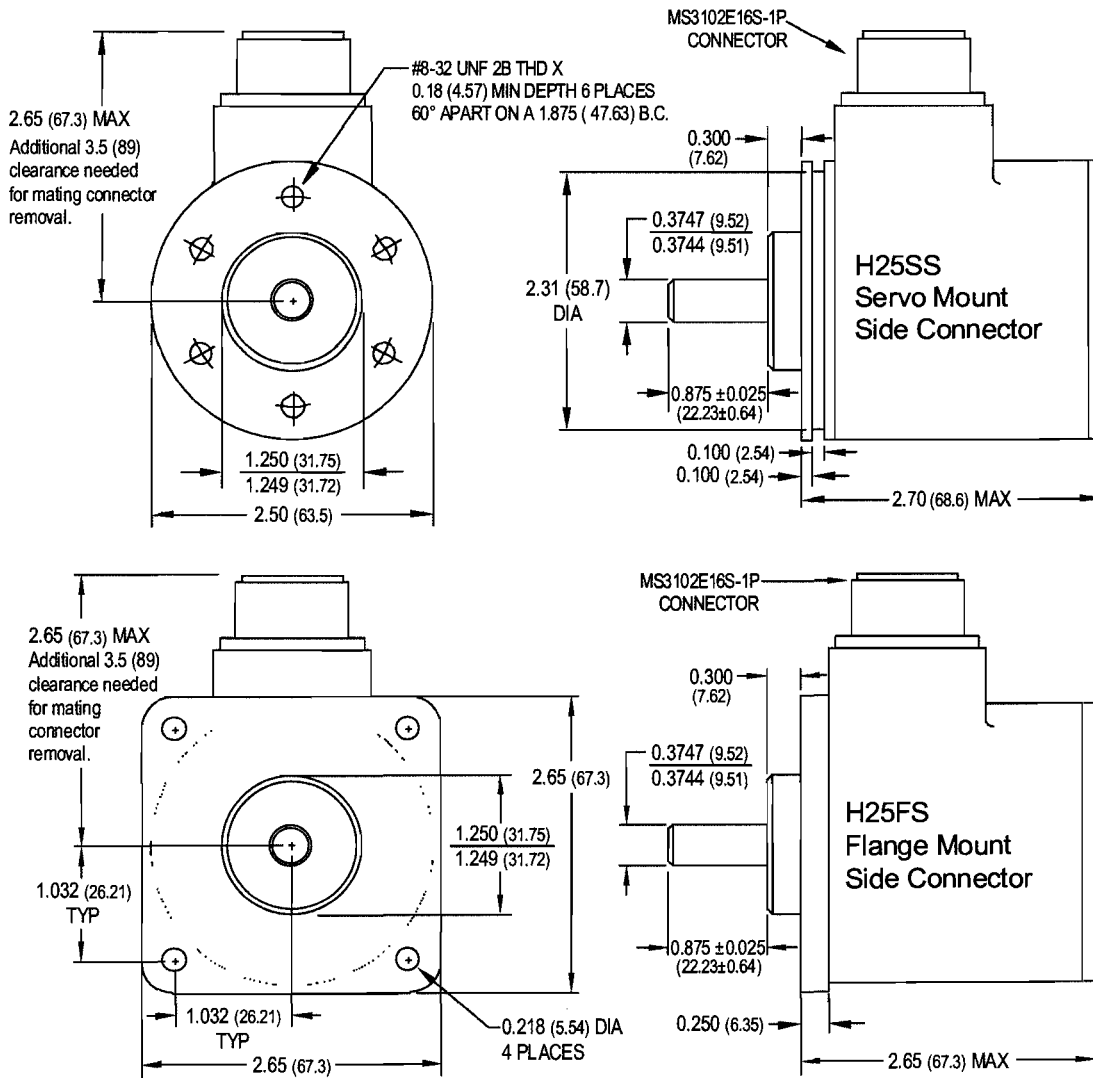

Figure 4.6 H25SS and H25SS Outline Drawing

INSTALLATION



Transducer Cable Installation

Every 8500 module uses the same transducer cable. Pre-assembled and tested cables can be ordered from AMCI under the part number *C1TP-(x)* where (x) is the length in feet. If you wish to make your own cables then mating connectors can be ordered from AMCI.

NOTE

- 1) Resolvers are low voltage, low power devices. If you are using A-B guidelines for cabling installation, treat the transducer cable as a Category 2 cable. It can be installed in conduit along with other low power cabling such as communication cables and low power ac/dc I/O lines. It cannot be installed in conduit with ac power lines or high power ac/dc I/O lines.
- 2) The shields of the transducer cable must be grounded at the 8500 module *only!* When installing the cable, treat the shield as a conductor. Do not connect the shield to ground at any junction box or the transducer. This will eliminate ground loops that could damage the module or PLC.

C1TP-(x) Wiring Diagram

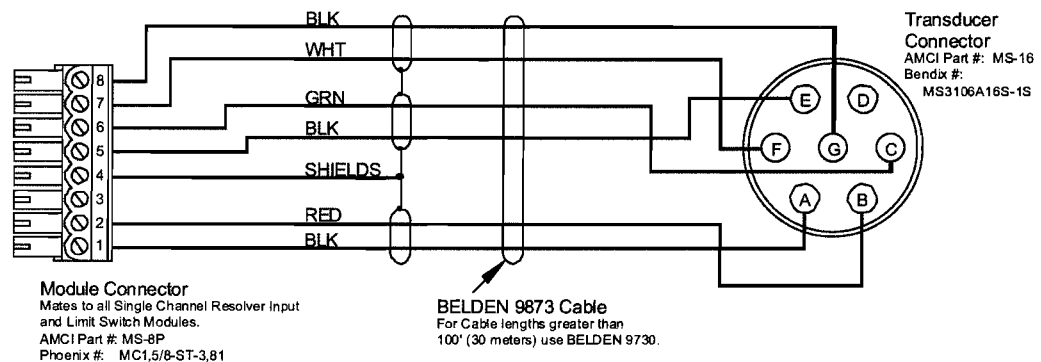

Figure 4.7 C1TP-(x) Wiring Diagram



Relay Board Installation

AMCI offers the *RB-7*, *RB-8* and *RB-9* relay boards for connecting Real I/O to the outside world. All relay boards require a separate +24Vdc supply for operation. The *RB-7* has space for eight solid state relay outputs. The *RB-8* has space for eight solid state relay outputs and eight inputs. Inputs are opto-isolated at the 8500. Two *RB-8*'s can be connected to give you a total of 16 I/O points or an *RB-8* and *RB-7* can be connected to give you a total of 8 inputs and 16 outputs. The *RB-9* has space for sixteen solid state relays. All three boards have an onboard relay fuse tester.

The relay boards can be DIN rail or panel mounted. They are shipped from AMCI in their DIN rail mount configuration and can be mounted on EN 50 022 or EN 50 035 channel. The procedure for converting them to panel mount is given below.

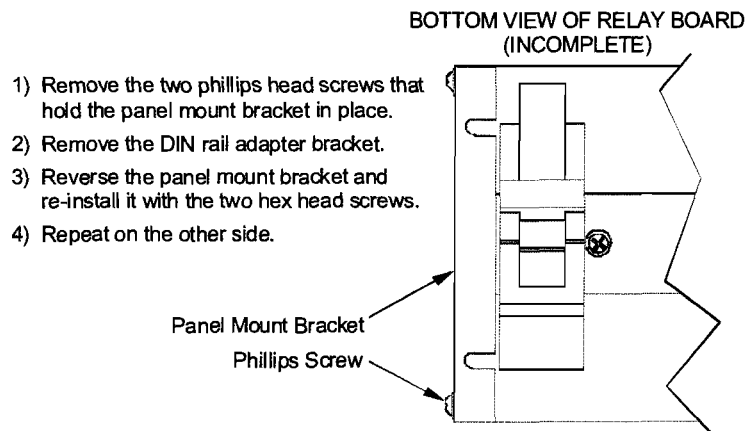

Figure 4.8 Relay Board Panel Mount Conversion

INSTALLATION



Relay Board Installation (continued)

RB-7 Outline Drawing

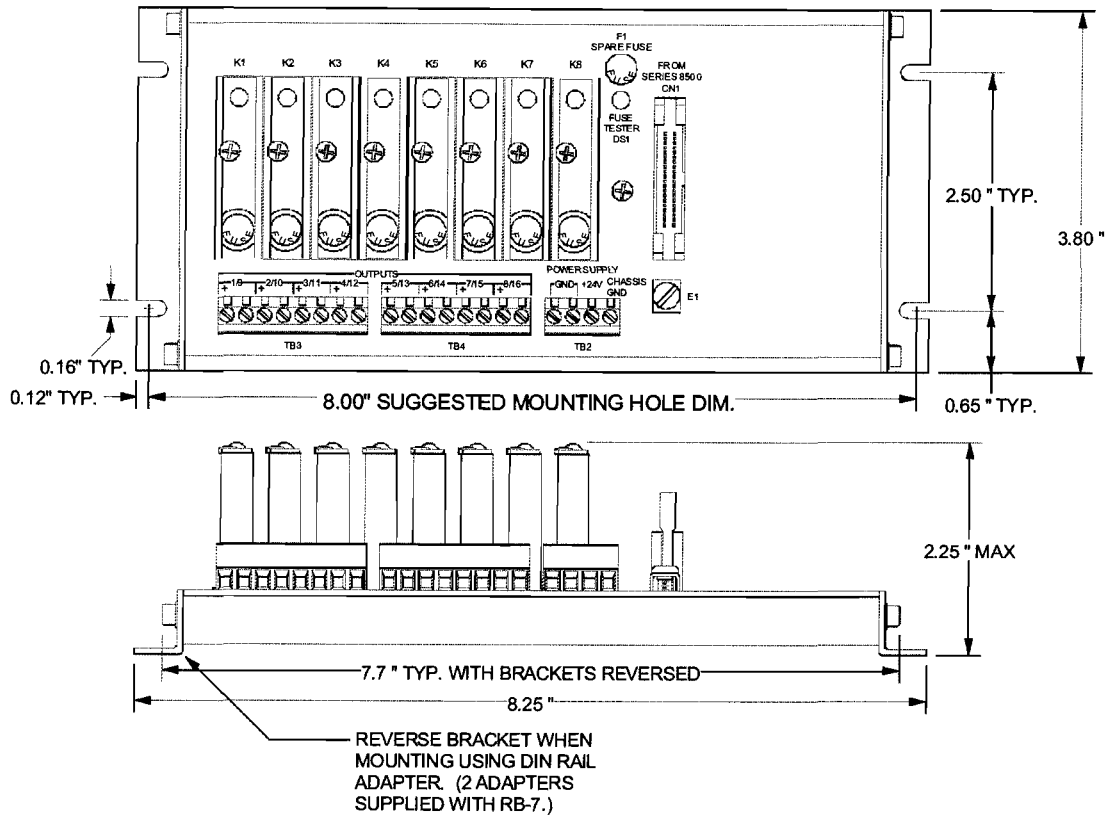

Figure 4.9 RB-7 Outline Drawing

Relay Board Installation (continued)

RB-8 Outline Drawing

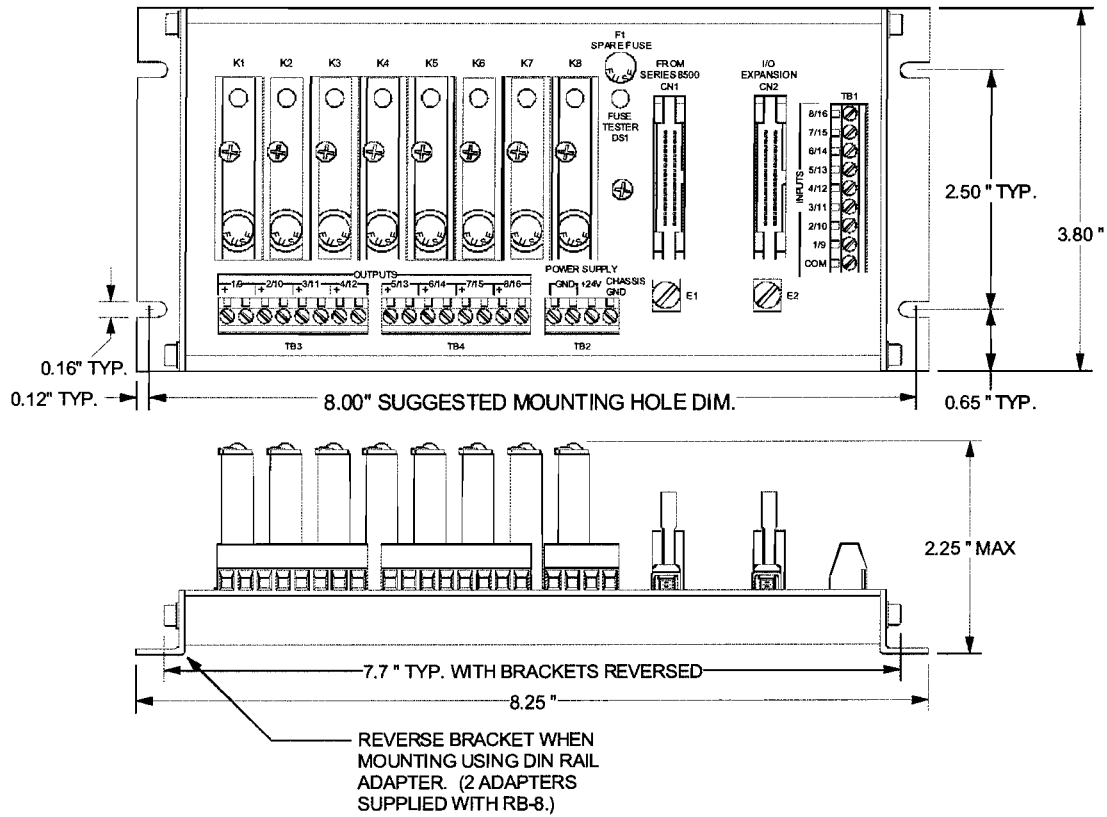

Figure 4.10 RB-8 Outline Drawing

INSTALLATION



Relay Board Installation (continued)

RB-9 Outline Drawing

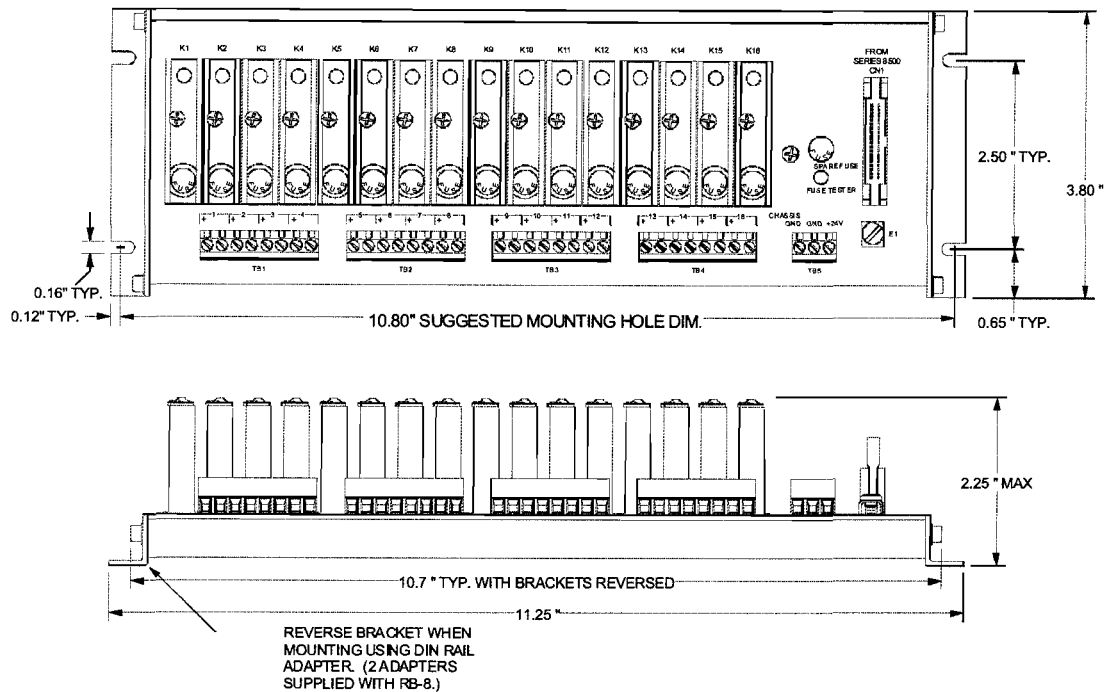

Figure 4.11 RB-9 Outline Drawing

Compatible Relays

Every output requires a solid state relay. These relays are OPTO 22 Generation 4 style relays that are fused protected, and have a retaining screw and indicator LED. These relays are available from AMCI under the following part numbers.

	Output Voltage	Rated Current
KD-6	3 - 60 Vdc	3 A dc
KA-3	120 Vac	3 A ac

Table 4.3 Compatible Relays



Relay Board Installation (continued)

Connecting the 8500 Module

Interconnections between the 8500 and relay boards are made with *CRP-(x)* cables, where (x) is the length in feet. Presently, two, six, and twelve foot cables are available from AMCI. CRP cables are shielded, fine pitch ribbon cables with drain lugs at both ends. Due to their complexity, AMCI strongly recommends that you purchase pre-assembled and tested CRP cables instead of making them yourself.

Connections are made by inserting the blue IDC connector into the proper socket and connecting the drain wire to the screw terminal. Note that the IDC connector is keyed and can only be inserted in one way. The retaining clips on the IDC socket snap over the top of the connector to secure it in place. The drain wire on the CRP cable must be connected to the screw terminals next to the IDC sockets. The screw terminal on the 8500 is connected to Earth Ground. The screw terminals on the RB-8 relay boards are connected together.

RB-8's have two IDC sockets which allows you to daisy chain a second relay board to it. (See Figure 4.12.)

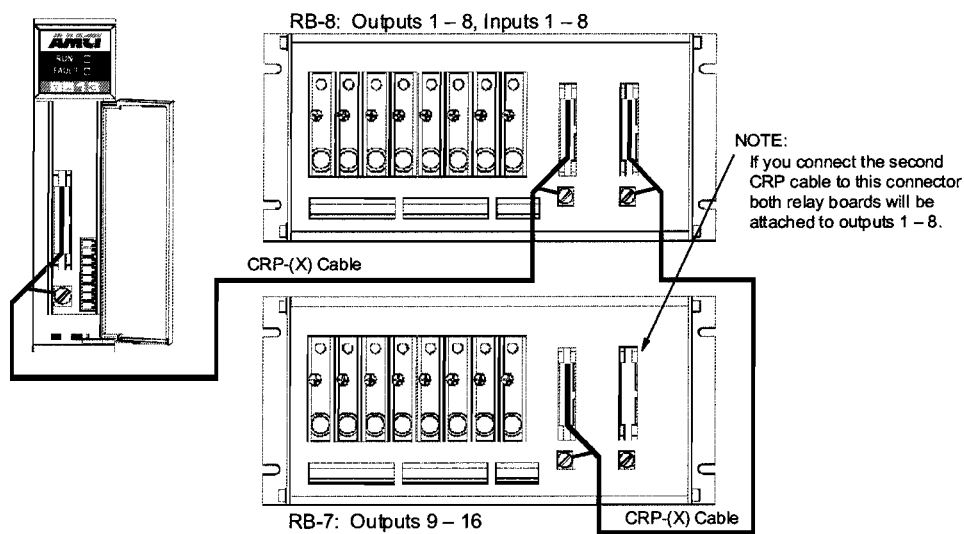

Figure 4.12 Daisy Chaining Relay Boards

The CRP cable from the 8500 is connected to the socket labeled "CN1" on the first RB-8. A second CRP cable is connected from the "CN2" socket of the first RB-8 to the "CN1" socket of either a RB-7 or RB-8. The first RB-8, the one connected to the 8500, has the Inputs and Outputs 1 - 8. If the second relay board is an RB-7, it has the Outputs 9 - 16. If the second relay board is an RB-8, it has the Inputs and Outputs 9 - 16.

INSTALLATION



Relay Board Installation (continued)

Connecting the External +24Vdc Supply

An external, isolated +24Vdc supply is needed to drive the inputs and relays. Connection to the relay boards is shown below along with maximum current draw. Note that these measurements are from the relay boards only. If you are using an RB-8 and powering the input sensors with the same supply, then you must add in the current requirements of each sensor to determine the power supply size.

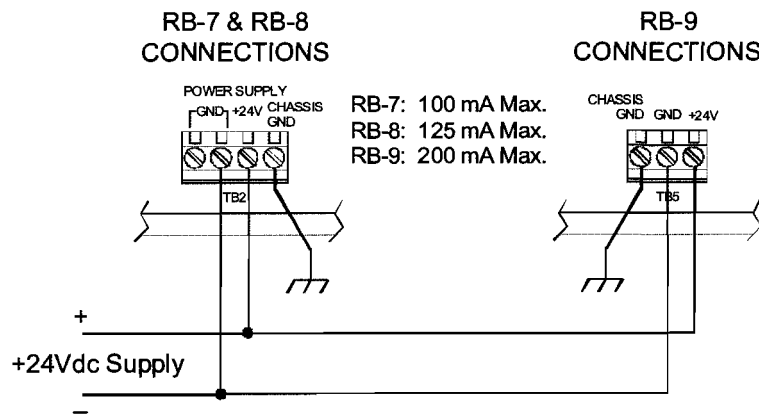

Figure 4.13 RB-8 & RB-9 Power Supply Connections

Chassis Ground

When a relay board is DIN rail mounted the case is isolated from the panel by the plastic DIN rail adapters. You *MUST* run a heavy gauge wire from the Chassis GND terminal of the power supply terminal block to your ground bus to ground the metal relay board case. When a relay board is panel mounted the case is usually connected to chassis ground through the mounting hardware. If you believe that the ground is insufficient then run a heavy gauge wire from the Chassis GND terminal to your ground bus.

RB-8 Sink / Source Inputs

The RB-8 inputs are connected to the TB1 terminal block. There are nine pins, one for each input and an Input Common. All inputs are opto-isolated and floating. That is, they are configured as sinking or sourcing inputs by connecting Input Common to a power supply. Typically, the +24Vdc supply that powers the output relays is also used to power the inputs. When Input Common is attached to +Vdc the inputs will source current into the sensors attached to them. When Input Common is attached to the power supply GND the inputs will sink current from the sensors attached to them.

If you are using all sixteen inputs they are split between the two RB-8's. Note that the two banks of inputs can be configured differently. For example, Inputs 1 – 8 can be configured as sinking inputs and Inputs 9 – 16 can be configured as sourcing inputs.



INSTALLATION

Notes



BACKPLANE PROGRAMMING

An 8500 module communicates with the SLC processor through two 'M' files as well as the Output and Input Image Tables. The 8500 is configured with data stored in its M0 and M1 data files. The Output Image Table is used to quickly adjust limit switch setpoints and force the 8500's I/O on or off. The Input Image Table is used to transmit position, tachometer, and limit switch status as well as global error information. This chapter details how to use this data to configure and run an 8500 module.

File Addressing

In this chapter, file addresses are defined in the following manner:

I:X.n Input Image Table
O:X.n Output Image Table
M0:X.n M0 file
M1:X.n M1 file

Where: 'X' is the slot number of the 8500 and 'n' is the word number in the file. When referring to a specific bit in a word, the characters "/bb" will be appended to the file address where 'bb' is the bit address.

Programming Cycle

Programming changes are written to the module with a Programming Cycle. All parameters, except for I/O Forces, are programmed through Programming Cycles. Programming Cycles are controlled with a Transmit Bit and associated Acknowledge Bit. In order to simplify programming, the Programmable Parameters are broken down into three groups. Therefore, there are three Transmit / Acknowledge Bit pairs that control the three Programming Cycle that setup the module. A fourth Transmit / Acknowledge Bit pair controls the Limit Switch Increment / Decrement Programming Cycle.

A Programming Cycle consists of six steps.

- 1) Write the new data in the correct memory locations. The programming data is stored in one of the two M files or the Output Image Table.
- 2) Set the appropriate Transmit Bit. The 8500 will not act on the new programming data until the Transmit bit is set.
- 3) Once the 8500 is done with the programming data it will set the appropriate Acknowledge Bit and any necessary error bits.
- 4) Once your ladder logic sees the Acknowledge Bit set, check for any errors.
- 5) Reset the Transmit Bit after you've responded to any errors.
- 6) The 8500 responds by resetting the Acknowledge Bit. The Programming Cycle is now complete.



Programming Groups

I/O Forces

I/O Forces are stored in the Output Image Table. The 8500 acts on these bits continuously. If one of these bits is set, the module will force the associated input or output within one processor scan time.

Setup Data: M0:X.0 – M0:X.19

All Transducer Setup Parameters and all Module Setup Parameters except for I/O Forces are stored in the M0 file between addresses M0:X.0 and M0:X.19. M0:X.0/15 is the Transmit Bit for this programming group. I:X.0/13 is the Acknowledge bit for this programming group.

Group Data: M0:X.20 – M0:X.99

All Group Set Parameters are stored in the M0 file between addresses M0:X.20 and M0:X.99. M0:X.20/15 is the Transmit Bit for this programming group. I:X.0/14 is the Acknowledge bit for this programming group.

Limit Switch Data: M1:X.0 – M0:X.629

All Limit Switch Setup Parameters are stored in the M1 file between addresses M1:X.0 and M1:X.629. M1:X.0/15 is the Transmit Bit for this programming group. I:X.0/15 is the Acknowledge bit for this programming group.

LS Increment / Decrement Data: O:X.0

This word in the Output Image Table give you the ability to increment or decrement limit switch setpoints while the machine is running to fine tune limit switch settings. O:X.0/15 is the Transmit Bit for the LS Increment / Decrement Data. I:X.0/12 is the Acknowledge Bit for the LS Increment / Decrement Data.

Error Handling

The 8500 stops accepting new parameters once it sets a programming error bit. How you respond to the error depends on your application. However, to reset the programming error in the 8500 you must go through a Programming Cycle with a Clear Errors bit set. Each programming group has a Clear Error bit but each one of these bits acts globally. Setting *any* of these bits will clear *all* of the errors in the module. Consider using the Clear Error bit in the Output Image Table. You do not need to write down any additional programming data when using this Clear Errors bit which give you the ability to write a single “Clear Errors” Programming Cycle that can be used at any time.

PROGRAMMING



Input Image Table

Figure 5.1 shows the format of the Input Image Table data. I:X.0 contain Error and Acknowledge Bits. The other data words contain position and tachometer data as well as limit switch and Real Input status data.

Input Image Table

	15	14	13	12	11	10	09	08	07	06	05	04	03	02	01	00
Word 0	LSAck	GPack	SUAck	I/Dack	0	TachOV	MD2	MD1	TrFit	ModFit	MsgIgn	I/DSet	I/DNum	LSEr	GPEr	SUEr
Word 1	Machine Position Data															
Word 2	Tachometer Data (Scaled Value)															
Word 3	Real LS Output Status (LS16 – LS1) [†]															
Word 4	Virtual LS Output Status (LS32 – LS17) [‡]															
Word 5	Real Input Status (IN16 – IN1) [*]															
Word 6	RESERVED: Set to zero.															
Word 7	RESERVED: Set to zero.															

[†] Bit 0 = LS1, Bit 1 = LS2, ... Bit 14 = LS15, Bit 15 = LS16

Always 0000h for 8511, 00FFh Max. for 8512.

[‡] Bit 0 = LS17, Bit 1 = LS18, ... Bit 14 = LS31, Bit 15 = LS32

^{*} Bit 0 = IN1, Bit 1 = IN2, ... Bit 14 = IN15, Bit 15 = IN16

Always 0000h for 8511, 00FFh Max. for 8512.

Figure 5.1 Input Image Table Data Format

Status Bits

SUErr: Setup Error, I:X.0/00. Because parameter values are not store in non-volatile memory, this bit is set on every power up. It is also set if there is an error in the setup programming data, M0:X.0 – M0:X.19, after a Programming Cycle tries to set these parameters. If this bit is set after a Programming Cycle, status bits in M0:X.100 – M0:X.109 show the exact error.

GPErr: Group Error, I:X.0/01. This bit is set if there is an error in the group programming data, M0:X.20 – M0:X.99, after a Programming Cycle tries to set these parameters. Status bits in M0:X.110 – M0:X.119 show the exact error.

LSErr: Limit Switch Error, I:X.0/02. This bit is set if there is an error in the limit switch programming data, M1:X.0 – M1:X.629, after a Programming Cycle tries to set these parameters. Status bits in M1:X.630 – M0:X.649 show the exact error.

I/DNum: Inc/Dec Output Number Error, I:X.0/03. Set when the number of the Limit Switch output being incremented or decremented is invalid. Also set if you do not specify which setpoint, or both, of the setpoint pair you wish to change.

I/DSet: Inc/Dec output Setpoint Error, I:X.0/04. Set when the limit switch output setpoint being incremented or decremented is invalid.



Input Image Table (continued)

Status Bits (continued)

- MsgIgn:** Message Ignored, I:X.0/05. Set when you attempt to program any parameter, except I/O Forces, and a programming error exists.
- ModFlt:** Module Fault, I:X.0/06. Set when the 8500 fails its power up self test. Cycle power to the module. If the fault remains the 8500 must be returned to AMCI for repairs.
- TrFlt:** Transducer Fault, I:X.0/07. Set when there is a transducer fault. Most common causes are the transducer not being attached or faulty transducer cabling.
- MD1:** Motion Detect 1, I:X.0/08. Set when the transducer velocity, in RPM, is within the setpoints programmed into Motion Detector 1.
- MD2:** Motion Detect 2, I:X.0/09. Set when the transducer velocity, in RPM, is within the setpoints programmed into Motion Detector 2.
- TachOv:** Tachometer Overflow, I:X.0/10. Set when the scaled tachometer data in I:X.2 exceeds 32,767. Above this value, the SLC interprets the data as a negative value.
- I/DAck:** Limit Switch Increment /Decrement Acknowledge Bit, I:X.0/12.
- SUAck:** Setup Programming Acknowledge Bit, I:X.0/13.
- GPAck:** Group Programming Acknowledge Bit, I:X.0/14.
- LSAck:** Limit Switch Programming Acknowledge Bit, I:X.0/15.

Output Image Table

The Output Image Table data is used to do the following:

- ▶ Word O:X.0 is used to increment or decrement limit switch setpoints. This gives you the ability to fine tune the setpoints while the machine is running.
- ▶ Words O:X.1 through O:X.4 are used to force any limit switch output on or off. You force an output by setting the appropriate bit. Force OFF bits take precedence over Force ON bits. For normal operation, these four words should equal 0000h.
- ▶ Word O:X.5 is the Virtual Inputs. Setting the bit to '1' activates the input.
- ▶ Words O:X.6 and O:X.7 are used to force the Real Inputs on or off. You force an input by setting the appropriate bit. Force OFF bits take precedence over Force ON bits. For normal operation, these two words should equal 0000h.

PROGRAMMING



Output Image Table (continued)

Figure 5.2 shows the format of the Output Image Table data.

		15	14	13	12	11	10	09	08	07	06	05	04	03	02	01	00
Word 0	I/DTMT	ClrErr	0	I/DSP	CgOFF	CgON	INC/DEC Setpoint Number				INC/DEC LS Number						
Word 1	Force ON: Real LS Outputs LS16 – LS1 [†]																
Word 2	Force ON: Virtual LS Outputs LS32 – LS17 [‡]																
Word 3	Force OFF: Real LS Outputs LS16 – LS1 [†]																
Word 4	Force OFF: Virtual LS Outputs LS32 – LS17 [‡]																
Word 5	Virtual Inputs: IN32 – IN17 [‡]																
Word 6	Force OFF: Real Inputs: IN16 – IN1 [†]																
Word 7	Force ON: Real Inputs: IN16 – IN1 [†]																

[†] Bit 0 = I/O1, Bit 1 = I/O2, ... Bit 14 = I/O15, Bit 15 = I/O16

[‡] Bit 0 = I/O17, Bit 1 = I/O18, ... Bit 14 = I/O31, Bit 15 = I/O32

Virtual Inputs not used in Independent Mode.

Figure 5.2 Output Image Table Data Format

Status Bits

INC/DEC LS Number: O:X.0/05 – O:X.0/00. These five bits make up a binary number that is the number of the limit switch whose setpoints you want to change. Maximum range is 1 to 32. However, setting these bits to a limit switch number that does not exist will result in an error. The error bit set is I/DNum, I:X.0/03.

INC/DEC Setpoint Number: O:X.0/09 – O:X.0/06. These four bits make up binary number that is the number of the setpoint pair you wish to adjust. Range of values is 1 to 9. Set these bits to 9 to change all of the setpoint pairs programmed on the output. Setting this number to 0, or greater than 9, or to a setpoint pair that is not programmed, will generate an error. The error bit set is I/DSet, I:X.0/04.

CgON: Change ON Setpoint, O:X.0/10. Set this bit to change the ON setpoint of the selected ON/OFF setpoint pair(s). This bit and the CgOFF bit can be set at the same time.

CgOFF: Change OFF Setpoint, O:X.0/11. Set this bit to change the OFF setpoint of the selected ON/OFF setpoint pair(s). This bit and the CgON bit can be set at the same time.

I/DSP: INC/DEC Setpoint, O:X.0/12. Set this bit to '0' to increment the selected setpoint(s). Set this bit to '1' to decrement the selected setpoint(s).

ClrErr: Clear Error Bit, O:X.0/14. When set to '1', the 8500 will clear all programming errors. It will also attempt to clear the transducer fault if one exists.

I/DTMT: Increment / Decrement Transmit Bit, O:X.0/15.



M0 File

The M0 File is broken down into four sections.

Setup Programming Data: M0:X.0 to M0:X.19. Used to preset the Machine Position as well as program all Transducer Setup Parameters and Module Setup Parameters except for the I/O Forces.

Group Programming Data: M0:X.20 to M0:X.99. Used to program all Group Setup Parameters for all six groups.

Setup Status Data: M0:X.100 to M0:X.109. Contains status data on the last Setup Programming Cycle.

Group Status Data: M0:X.110 to M0:X.119. Contains status data on the last Group Programming Cycle as well as current group positions.

M0 File / Setup Programming Data

Figure 5.3 shows the format of the Setup Programming Data. Word M0:X.0 contains bit value parameters, a Clear Errors bit and a transmit bit. The other words in the data contain the rest of the programmable parameters.

M0 File / Setup Data

	15	14	13	12	11	10	09	08	07	06	05	04	03	02	01	00
Word 0	SDTMIT	0	0	0	0	MType	SLCINT	0	0	TRsp	CDIr	0	0	Preset	ChEr	
Word 1	Scale Factor (2 to 1024)															
Word 2	Preset Value (0 to SF-1)															
Word 3	Machine Offset [†] (0 to SF-1)															
Word 4	Motion Detector 1 Low RPM (0 to 32,767)															
Word 5	Motion Detector 1 High RPM (0 to 32,767)															
Word 6	Motion Detector 2 Low RPM (0 to 32,767)															
Word 7	Motion Detector 2 High RPM (0 to 32,767)															
Word 8	Real Input Active State (IN16 – IN1) [‡]															
Word 9	Tach Multiplier (0 to 1100)															
Word 10	Tach Divisor (0 to 63, 0 only if Tach Mul. = 0)															
Word 11	Tach Decimal Point (0 to 3, Divide by 10 ^{DP})															
Words 12–19	RESERVED: Must equal 0000h															

[†] In order to keep the Machine Position absolute, the Machine Offset must be set equal to the value reported in M0:X.101 before setting the Setup Data Transmit Bit.

[‡] Bit 0 = IN1, Bit 1 = IN2, ... Bit 14 = IN15, Bit 15 = IN16. Setting the bit to '0' makes the input act like a normally closed relay. Setting the bit to '1' makes the input act like a normally open relay.

Figure 5.3 Setup Programming Data Format

PROGRAMMING



M0 File / Setup Programming Data (continued)

Status Bits

- ClrErr: Clear Errors, M0:X.0/00. When set to '1', the 8500 will clear all programming errors. It will also attempt to clear the transducer fault if one exists.
- Preset: Preset Machine Position, M0:X.0/01. Set to '1' to preset the Machine Position to the Preset Value in word M0:X.2.
- CDir: Count Direction, M0:X.0/04. Set to '0' for CW increasing position count. Set to '1' for CCW increasing position count.
- TResp: Tach Response, M0:X.0/05. Set to '0' for 504 mSec update time. Set to '1' for 120 mSec update time. This update time applies to the tachometer data reported over the backplane and the ON/OFF status of the motion detectors.
- SLCINT: SLC Interrupt, M0:X.0/08. Set to '0' to disable the SLC Interrupt capability. Set to '1' to enable the interrupt.
- MType: Module Type, M0:X.0/09. Set to '0' for Group Mode. Set to '1' for Independent Mode.
- SDTMT: Setup Data Transmit, M0:X.0/15.

M0 File / Setup Status Data

Figure 5.4 shows the format of the Setup Status Data. Word M0:X.100 contains detailed status bits of the last Setup Programming Cycle. A general error bit in the Input Image Table, SUErr, I:X.0/00, is set on any error in the Setup Programming Data. Your ladder logic should check this error bit first. If it is set, word M0:X.100 will set bits that help you pinpoint the error.

Word M0:X.101 is the calculated Machine Offset. This value changes every time the machine Position is preset. In order to keep the Machine Position absolute, you must copy this value into the Machine Offset word in the Setup Programming Data before performing a Setup Programming Cycle.

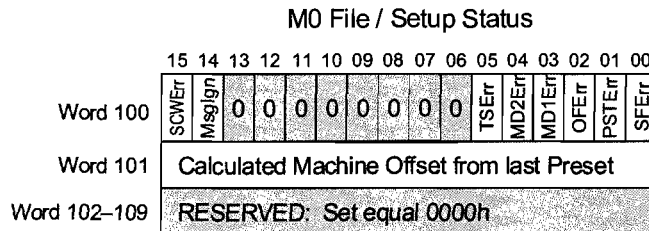

Figure 5.4 Setup Status Data Format



M0 File / Setup Status Data (continued)

Status Bits

- SFErr:** Scale Factor Error, M0:X.100/00. Set when the Scale Factor value is outside the range of 2 to 1024.
- PSTErr:** Preset Value Error, M0:X.100/01. Set when the Preset Value is outside the range of 0 to (SF-1).
- OFErr:** Machine Offset Error, M0:X.100/02. Set when the Machine Offset value is outside the range of 0 to (SF-1).
- MD1Err:** Motion Detector 1 Error, M0:X.100/03. Set if one or both Motion Detector 1 setpoints are outside the range of 0 to 32,767 or if the setpoint are equal but not zero.
- MD2Err:** Motion Detector 2 Error, M0:X.100/04. Set if one or both Motion Detector 2 setpoints are outside the range of 0 to 32,767 or if the setpoint are equal but not zero.
- TSErr:** Tachometer Scalars Error, M0:X.100/05. Set if the Tach Multiplier, Tach Divisor, or Tach Decimal Point are outside their programmable ranges.
- MsgIgn:** Message Ignored, M0:X.100/14. Set when you attempt to program any parameter, except I/O Forces, and a programming error exists.
- SCWErr:** Setup Command Word Error. One or more of the reserved bits in M0:X.0 are set to '1'. These bits must always equal '0'.

PROGRAMMING



M0 File / Group Programming Data

Figure 5.5 shows the format of the Group Programming Data. Word M0:X.20 contain a Clear Errors bit and the Group Data Transmit bit. The rest of the words are split into six blocks for four words each.

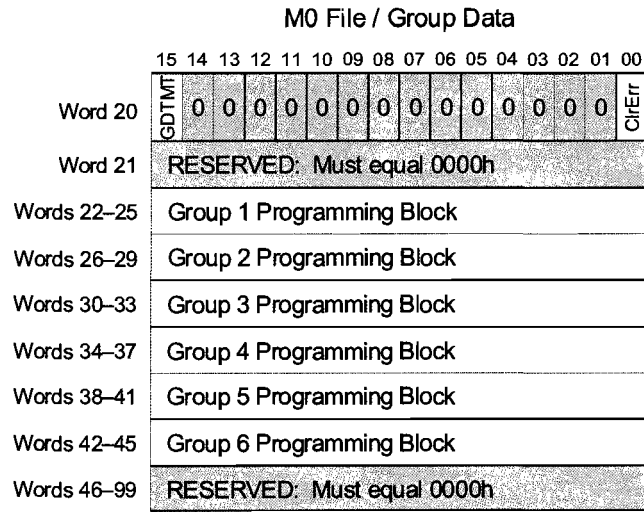

Figure 5.5 Group Programming Data Format

Status Bits

ClrErr: Clear Errors, M0:X.20/00. When set to '1'. The 8500 will clear all programming errors. It will also attempt to clear the transducer fault if one exists.

GDTMT: Group Data Transmit, M0:X.20/15.



M0 File / Group Programming Data (continued)

Group Block Format

The six blocks program the six output groups. The format of each block is identical. A single block is shown in figure 5.6.

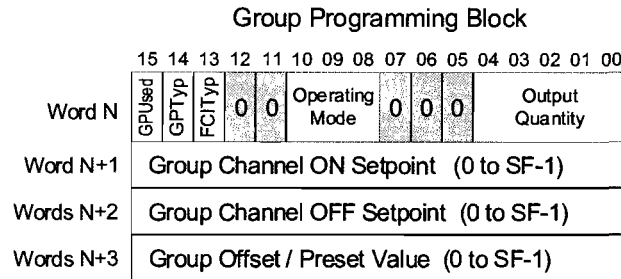

Figure 5.6 Group Block Data Format

Status Bits

Output Quantity: M0:X.N/04–M0:X.N/00. These six bits program the Output Quantity parameter for the group. Valid range of 1 to 16.

Operating Mode: M0:X.N/10–M0:X.N/08. These three bits program the Operating Mode for the group. Valid range is 0 to 5.

FCITyp: First Cycle Input Type, M0:X.N/13. Programs the First Cycle Input Type parameter for the group. Set to ‘0’ for the Real Input, ‘1’ for the Virtual input. This parameter is only significant when the group is in Mode 5. Because the 8511 has no Real Inputs, this bit must be set to ‘1’ when using a group in Mode 5 with this module.

GPTyp: Group Type, M0:X.N/14. Programs the Group Type parameter for the group. Set to ‘0’ for Real I/O, ‘1’ for Virtual I/O. Because the 8511 has no Real Inputs, this bit must be set to ‘1’ when using this module.

GPU_{Used}: Group Used, M0:X.N/15. This bit must be set to ‘1’ when using the group. Set to ‘0’ to disable the group. When set to ‘0’, all other parameters in the block are ignored.

PROGRAMMING



M0 File / Group Status Data

Figure 5.7 shows the format of the Group Status Data. Words M0:X.110 and M0:X.111 contain detailed status bits on the last Group Programming Cycle. A general error bit in the Input Image Table, GPErr, I:X.0/01, is set on any error in the Group Programming Data. Your ladder logic should check this error bit first. If it is set, words M0:X.110 and M0:X.111 will set bits that help you pinpoint the error.

Words M0:X.112 through M0:X.117 contain the Group Position values.

		15	14	13	12	11	10	09	08	07	06	05	04	03	02	01	00
Word 110	GCWEr	Msglgn	0	0	0	0	0	0	0	0	0	0	0	0	GCSEr	GPgEr	GOFEr
Word 111	Group Number with Error																
Word 112	Group 1 Position Value																
Word 113	Group 2 Position Value																
Word 114	Group 3 Position Value																
Word 115	Group 4 Position Value																
Word 116	Group 5 Position Value																
Word 117	Group 6 Position Value																
Word 118–119	RESERVED: Set equal 0000h																

Figure 5.7 Group Status Format

Status Bits

- GOFEr:** Group Offset/Preset Error, M0:X.110/00. Set if the Group Offset / Preset value is outside the range of 0 to (SF-1).
- GPgEr:** Group Programming Error, M0:X.110/01. Set if the Output Quantity or Operating Mode parameter is invalid. 8511 and 8512 modules set this bit if you attempt to assign Real outputs to a group if the Real outputs are not available on the module.
- GCSEr:** Group Channel Setpoint Error, M0:X.110/02. Set when the one or both of the Group Channel Setpoints are outside the range of 0 to (SF-1) or both setpoints are equal but not zero.
- Msglgn:** Message Ignored, M0:X.110/14. Set when you attempt to program any Group Setup Parameter while an error exists. Also set if you program Group Setup parameters while the 8500 is in Independent Mode.
- GCWEr:** Group Command Word Error, M0:X.110/15. Set when one or more of the reserved bits in M0:X.20 are set to '1'. They must always equal zero.
- Word M0:X.111:** If any of the M0:X.110/00 through M0:X.110/02 bits are set, this word is set equal to the group number that has the error.



M1 File / Limit Switch Programming Data

Figure 5.8 shows the format of the Limit Switch Programming Data. Word M1:X.0 contains a Clear Errors bit and the Limit Switch Transmit bit. The rest of the words are split into thirty-two blocks of nineteen words each. Each block programs one of the limit switch outputs.

Status Bits

- ClrErr:** Clear Errors, M1:X.0/00. When set to '1'. The 8500 will clear all programming errors. It will also attempt to clear the transducer fault if one exists.
- LSTMT:** Limit Switch Transmit bit, M1:X.0/15.

		M1 File / Limit Switch Data															
		15	14	13	12	11	10	09	08	07	06	05	04	03	02	01	00
Word 0	LSTMT	0	0	0	0	0	0	0	0	0	0	0	0	0	0	0	ClrErr
Word 1	RESERVED: Must equal 0000h																
Word 2-20	Limit Switch 1 Programming Block																
Word 21-39	Limit Switch 2 Programming Block																
Word 40-58	Limit Switch 3 Programming Block																
Word 59-77	Limit Switch 4 Programming Block																
Word 78-96	Limit Switch 5 Programming Block																
Word 97-115	Limit Switch 6 Programming Block																
Word 116-134	Limit Switch 7 Programming Block																
Word 135-153	Limit Switch 8 Programming Block																
Word 154-172	Limit Switch 9 Programming Block																
Word 173-191	Limit Switch 10 Programming Block																
Word 192-210	Limit Switch 11 Programming Block																
Word 211-229	Limit Switch 12 Programming Block																
Word 230-248	Limit Switch 13 Programming Block																
Word 249-267	Limit Switch 14 Programming Block																
Word 268-286	Limit Switch 15 Programming Block																
Word 287-305	Limit Switch 16 Programming Block																
Word 306-324	Limit Switch 17 Programming Block																
Word 325-343	Limit Switch 18 Programming Block																
Word 344-362	Limit Switch 19 Programming Block																
Word 363-381	Limit Switch 20 Programming Block																
Word 382-400	Limit Switch 21 Programming Block																
Word 401-419	Limit Switch 22 Programming Block																
Word 420-438	Limit Switch 23 Programming Block																
Word 439-457	Limit Switch 24 Programming Block																
Word 458-476	Limit Switch 25 Programming Block																
Word 477-495	Limit Switch 26 Programming Block																
Word 496-514	Limit Switch 27 Programming Block																
Word 515-533	Limit Switch 28 Programming Block																
Word 534-552	Limit Switch 29 Programming Block																
Word 553-571	Limit Switch 30 Programming Block																
Word 572-590	Limit Switch 31 Programming Block																
Word 591-609	Limit Switch 32 Programming Block																
Word 610-629	RESERVED: Must equal 0000h																

Figure 5.8 Limit Switch Programming Data

PROGRAMMING



M1 File / Limit Switch Programming Data (continued)

Limit Switch Programming Block

The thirty-two blocks program the thirty-two limit switch outputs. The format of each block is identical. A single block is shown in figure 5.9. If you are using an 8511 or 8512 then the data in the unavailable limit switches is not acted on.

		M1 File / Limit Switch Data																
		15	14	13	12	11	10	09	08	07	06	05	04	03	02	01	00	
Word N	OEAnd Motion ANDing	0	0	0	0	0	0	0	0	0	0	0	0	0	0	LS Type		
Word N+1	ON Advance (±99.9 mS max. 0.1 mS Steps)																	
Word N+2	OFF Advance (±99.9 mS max. 0.1 mS Steps)																	
Word N+3	Normal: ON Setpoint 1	OR										Timed: ON Setpoint 1	OR					Pulsed: Leading Edge
Word N+4	Normal: OFF Setpoint 1											Timed: OFF Setpoint 1						Pulsed: Trailing Edge
Word N+5	Normal: ON Setpoint 2											Timed: Duration in mS						Pulsed: Pulse Quantity
Word N+6	Normal: OFF Setpoint 2											Timed: Not Used						Pulsed: ON Count
Word N+7	Normal: ON Setpoint 3											Timed: Not Used						Pulsed: Not Used
Word N+8	Normal: OFF Setpoint 3											Timed: Not Used						Pulsed: Not Used
Word N+9	Normal: ON Setpoint 4											Timed: Not Used						Pulsed: Not Used
Word N+10	Normal: OFF Setpoint 4											Timed: Not Used						Pulsed: Not Used
Word N+11	Normal: ON Setpoint 5											Timed: Not Used						Pulsed: Not Used
Word N+12	Normal: OFF Setpoint 5											Timed: Not Used						Pulsed: Not Used
Word N+13	Normal: ON Setpoint 6											Timed: Not Used						Pulsed: Not Used
Word N+14	Normal: OFF Setpoint 6											Timed: Not Used						Pulsed: Not Used
Word N+15	Normal: ON Setpoint 7											Timed: Not Used						Pulsed: Not Used
Word N+16	Normal: OFF Setpoint 7											Timed: Not Used						Pulsed: Not Used
Word N+17	Normal: ON Setpoint 8											Timed: Not Used						Pulsed: Not Used
Word N+18	Normal: OFF Setpoint 8											Timed: Not Used						Pulsed: Not Used

Figure 5.9 LS Programming Block Format.

Parameter Values

LS Type, M1:X.N/01 & M1:X.N/00. Sets the Limit Switch Type Parameter for the output.

Bit 1	Bit 0	
0	0	LS Output not used.
0	1	Pulse LS Output
1	0	Timed LS Output
1	1	Normal LS Output

Motion ANDing, M1:X.N/14 & M1:X.N/13. Sets the Motion ANDing Parameter for the output.

Bit 14	Bit 13	
0	0	Motion ANDing not used
0	1	AND with MD1
1	0	AND with MD2
1	1	RESERVED, Do not use.



M1 File / Limit Switch Programming Data (continued)

Parameter Values (continued)

Enable ANDing, M1:X.N/15. If in Group Mode, set the value of the Enable ANDing Parameter for the output. Set to '0' if not using the Enable Input ANDing with this output. Set to '1' to tie this output with the LS Enable Input. This bit is not used or checked if the module is in Independent Mode.

ON Advance, M1:X.N+1. Sets the value of the outputs ON Advance. Range is ± 99.9 mSec with 0.1 mSec resolution (± 999 counts)

OFF Advance, M1:X.N+2. Sets the value of the outputs OFF Advance. Range is ± 99.9 mSec with 0.1 mSec resolution. (-999 to +999)

The meaning of the remaining words depends on the type of output being programmed.

All ON / OFF Setpoints are programmable from 0 to SF-1.

Timed Output Duration, M1:X.N+5. Programmable to 9.999 seconds with 1 mSec resolution. (0 to 9,999)

Pulsed Leading/Trailing Edges, M1:X.N+3 & N+4. Setpoints that set the leading edge and trailing edge of the pulse train. Programmable from 0 to SF-1.

Pulsed Pulse Number, M1:X.N+5. The number of pulses in the pulse train.

Pulsed ON Count, M1:X.N+6. The number of counts each pulse is on. The difference between the Leading and Trailing Edge setpoints must be greater than or equal to ((Pulse Qty * ON Count) + (Pulse Qty -1)).

PROGRAMMING



M1 File / Limit Switch Status Data

Figure 5.10 show the format of the Limit Switch Status Data. Word M1:X.630 contains detailed status bits on the last LS Programming Cycle. A general error bit in the Input Image Table, LSErr, I:X.0/02, is set on any error in the LS Programming Data. Your ladder logic should check this error bit first. If it is set, M1:X.630 will set bits that help you pinpoint the error.

When the error involves a limit switch, Word M1:X.631 contains the LS Number that has the error. If the error involves limit switch setpoints, Word M1:X.632 contain the number of the setpoint pair that has the error.

		15	14	13	12	11	10	09	08	07	06	05	04	03	02	01	00
Word 630	LOWEr MsgIn	0	0	0	0	0	0	LSDis	0	0	POErr	NTErr	TmdErr	AdvErr	OffErr	OnErr	
Word 631	Output Error Number																
Words 632	Setpoint Error Number																
Words 633-649	RESERVED: Set equal to 0000h																

Figure 5.10 LS Status Data

Status Bits

- OnErr:** ON Setpoint Error, M1:X.630/00. Set when an ON setpoint is outside the range of (0 to SF-1). Check Words M1:X.631 & 632 for Output and Setpoint numbers.
- OffErr:** OFF Setpoint Error, M1:X.630/01. Set when an OFF setpoint is outside the range of (0 to SF-1). Check Words M1:X.631 & 632 for Output and Setpoint numbers.
- AdvErr:** Advance Error, M1:X.630/02. Set when an Advance is outside the range of ± 999 . Check Word M1:X.631 for the Output number.
- TmdErr:** Timed Duration Error, M1:630/03. Set when an Timed Duration is outside the range of (0 to 9999). Check Word M1:X.631 for the Output number.
- NTErr:** Number of Timed Outputs Exceeded, M1:X.630/04. Set when you try to program more than four Timed outputs. Word M1:x.631 contains the Output number of the fifth limit switch programmed as a Timed output.
- POErr:** Pulsed Output Error, M1:X.630/05. There is an error with one or more of your Pulsed Output Parameters. The difference between the Leading and Trailing Edge setpoints is less than $((\text{Pulse Qty} * \text{ON Count}) + (\text{Pulse Qty} - 1))$.
- LSDis:** LS Disabled, M1:X.630/08. Set to '1' when the outputs are disabled because the 8500 has not been configured or there is a transducer fault.



M1 File / Limit Switch Status Data (continued)

Status Bits (continued)

Msglgn: Message Ignored, M1:X.630/14. Set when you attempt to program a LS Setup Parameters while an error exists.

LCWErr: LS Command Word Error, M1:X.630/15. Set under three conditions:

- 1) One of more if the reserved bits in M1:X.0 are set to '1'. They must always equal zero.
- 2) You set both Motion ANDing bits in the Limit Switch Programming Block to '1'. You cannot assign both motion detectors to a single limit switch.
- 3) When in Group Mode, this bit is set if you attempt to program a limit switch that has not been assigned to a group.

PROGRAMMING EXAMPLE

The following ladder logic program is an example of how an 8500 module can be programmed and monitored from the SLC processor.

```
Rockwell Software Incorporated
  9323 Series Software
  APS Release 6.01
  Documentation Utility
  Program Listing
```

```
8500 Example Program
```

```
Processor File: 8500EXAM.ACH
June 18, 1997 - 15:54
```



PROGRAMMING EXAMPLE

8500 Example Program
Program Listing

Processor File: 8500EXAM.ACH

June 18, 1997 Page 1
Rung 2:0

Rung 2:0

At power up, the 8500 module will set input word 0, bit 5, to indicate that the module is not setup. If this input bit is set, the following rung will COPY the setup data contained in registers N10:1 through N10:12, and then MOVE the command word, N10:0, to the M0 registers defined for the setup data. The setup data can also be sent to the module by manually setting bit N7:0/0. The module will set input word 0, bit 13, to indicate that the transfer is complete.

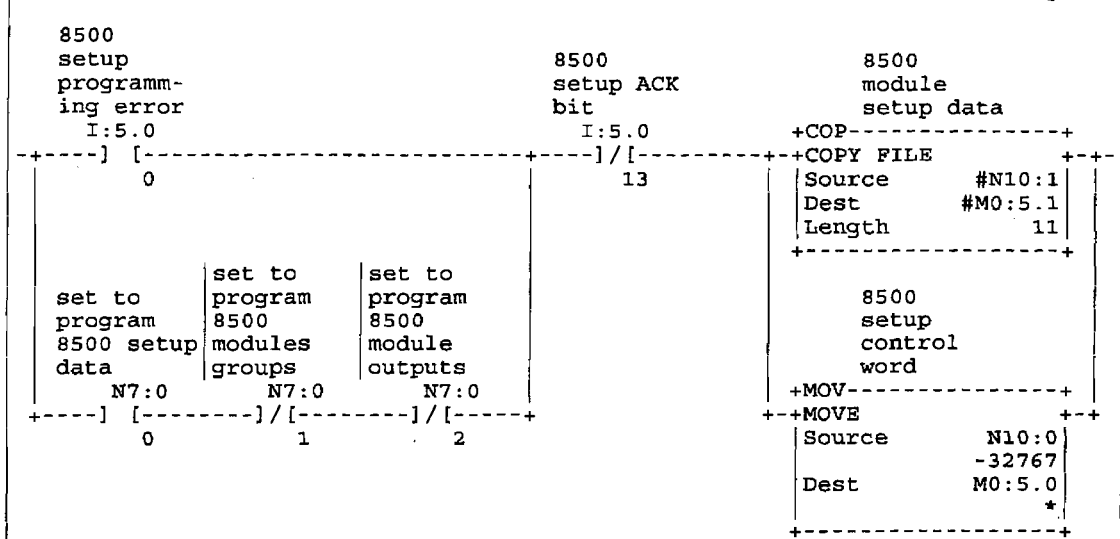

Rung 2:1

The following rung will automatically program the 8500 module's groups after the setup data has been programmed by the above rung. The groups can also be programmed by manually setting bit N7:0/1. The data contained in registers N10:20 through N10:26 programs the module for only one group. The module will set input word 0, bit 14, to indicate that the transfer is complete.

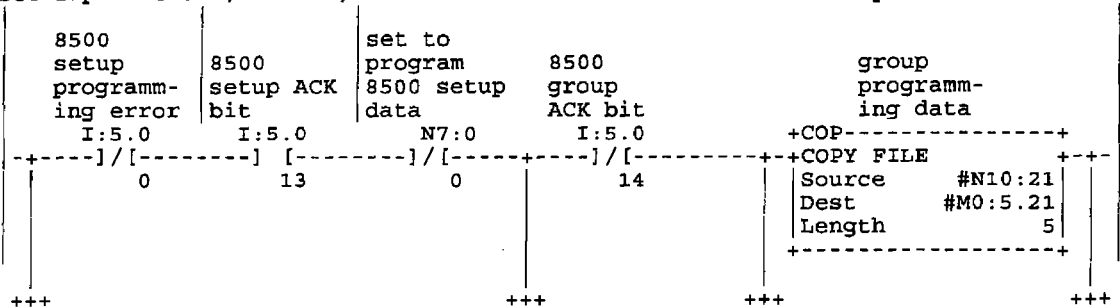

PROGRAMMING EXAMPLE



8500 Example Program
Program Listing

Processor File: 8500EXAM.ACH

June 18, 1997 Page 4
Rung 2:4

Rung 2:4

When the 8500 module's group data has been programmed, move a zero to the group programming command word's M0 location. This operation completes the group programming cycle, so that another transfer can take place. Bit N7:0/1, which initiates programming the group data manually, is also reset by this rung.

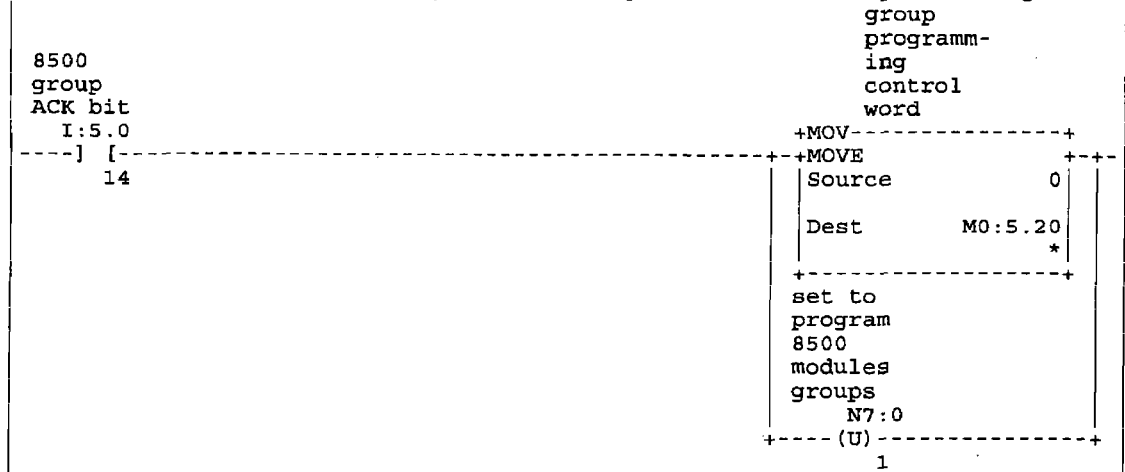

Rung 2:5

When the 8500 module's output data has been programmed, move a zero to the output programming command word's M1 location. This operation completes the output programming cycle, so that another transfer can take place. Bit N7:0/2, which initiates programming the output data manually, is also reset by this rung.

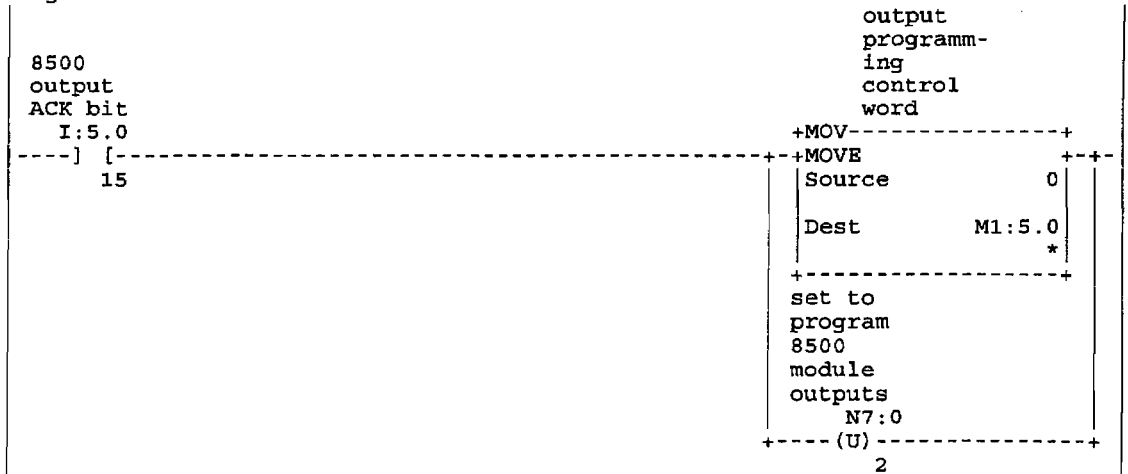

6

PROGRAMMING EXAMPLE

8500 Example Program
Program Listing

Processor File: 8500EXAM.ACH

June 18, 1997 Page 5
Rung 2:6

Rung 2:6

If the output number, or the output setpoint number, to be incremented or decremented is invalid, set bit B3:0/0 to indicate the error.

increment/ decrement output number		set when increment/ decrement values invalid B3:0
+GRT-----+		()
+--GREATER THAN		0
Source A N7:2		
0		
Source B 32		
+-----+		
increment/ decrement setpoint value		
+GRT-----+		
+--GREATER THAN		
Source A N7:3		
0		
Source B 9		
+-----+		

Rung 2:7

set when increment/ decrement values invalid B3:0	set when increment/ decrement to occur N7:1	program 4 increments decrements outputs
-----/ [-----]	[-----]	+JSR-----+
0 3		+JUMP TO SUBROUTINE+
		SBR file number 4
		+-----+

Rung 2:8

set when increment/ decrement to occur N7:1		set to increment/ decrement output O:5.0
-----] [-----]		()
3		15

PROGRAMMING EXAMPLE



8500 Example Program
Program Listing

Processor File: 8500EXAM.ACH

June 18, 1997 Page 6
Rung 2:9

Rung 2:9

If an error is detected with any of the 8500 module's programming, jump to subroutine 3, which is an error handling routine. Please note, the contents of this subroutine are not shown in this example. The user must write a subroutine to handle his specific application.

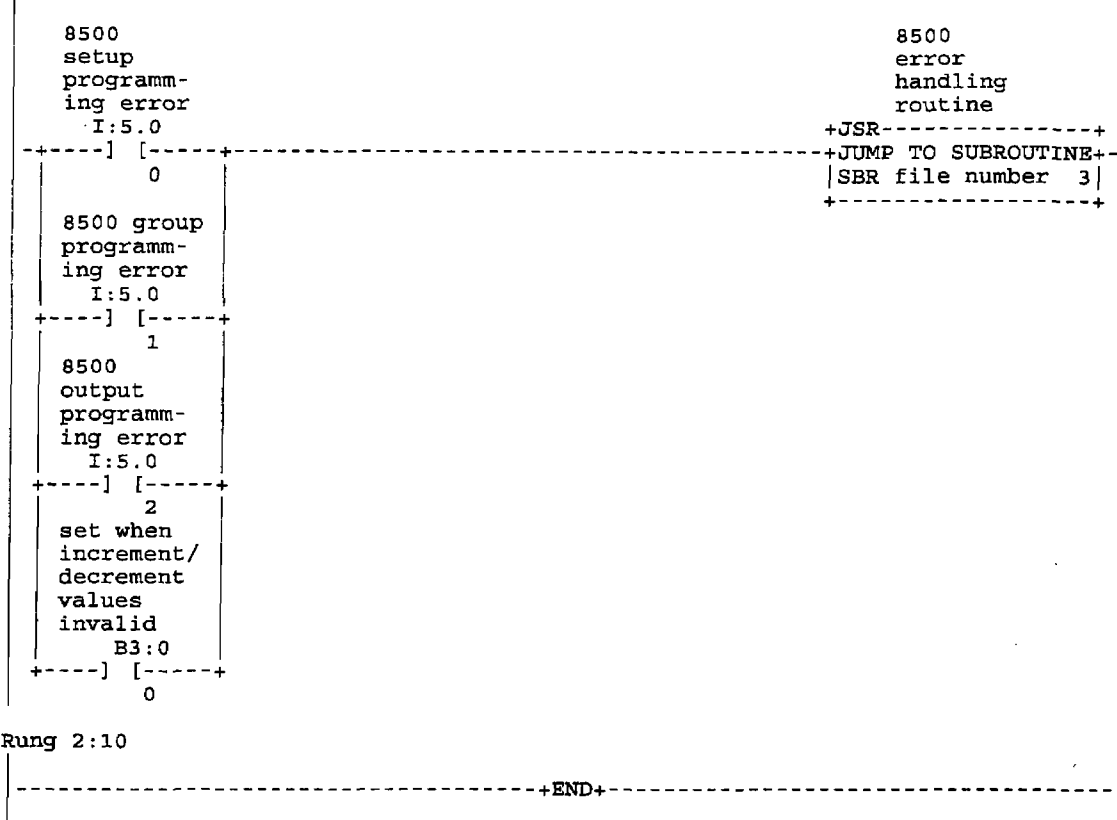

6

PROGRAMMING EXAMPLE

8500 Example Program
Program Listing

Processor File: 8500EXAM.ACH

June 18, 1997 Page 7
Rung 4:0

Rung 4:0

Shift the output setpoint number from bits 0 through 3 of the source word to bits 6 through 9 of the destination word.

		setpoint value bit shifted to right
		+MUL-----+
		+MULTIPLY +
Source A	N7:3	0
Source B	64	
Dest	N7:4	0
		+-----+

Rung 4:1

Combine the output number and the shifted setpoint number into one word by ORing the output word with the shifted setpoint number.

		combined output and setpoint value
		+OR-----+
		+BITWISE INCLUS OR +
Source A	N7:2	0
Source B	N7:4	0
Dest	N7:5	0
		+-----+

Rung 4:2

set to change output on setpoint N7:1	set to change output on setpoint N7:5
-----] [-----	-----] ()-----
0	10

Rung 4:3

set to change output off setpoint N7:1	set to change output off setpoint N7:5
-----] [-----	-----] ()-----
1	11

PROGRAMMING EXAMPLE



8500 Example Program
Program Listing

Processor File: 8500EXAM.ACH

June 18, 1997 Page 9
Rung 4:4

```
Rung 4:4
0=incre-          0=incre-
ment              ment
1=decre-          1=decre-
ment              ment
  N7:1            N7:5
---] [-----] ( )
      2                      12
```

```
Rung 4:5
                                     8500
                                     module
                                     output
                                     image
                                     table
                                     +MOV-----+
-----+MOVE-----+
      Source      N7:5
      Dest        O:5.0
                                     +-----+
                                     +-----+
```

```
Rung 4:6
                                     +RET-----+
-----+RETURN-----+
                                     +-----+
```

```
Rung 4:7
-----+END+-----
```



8500 Example Program
Data Table

Processor File: 8500EXAM.ACH

June 18, 1997 Page 1
Data Table File N10

Address	Data (Radix=DECIMAL)									
N10:0	-32767	1024	0	0	50	60	80	105	-1	0
N10:10	0	0	0	0	0	0	0	0	0	0
N10:20	-32767	0	-32253	1000	1020	0	0	0	0	0
N10:30	-32767	0	3	0	0	100	120	500	505	0
N10:40	3	10	10	200	225	0	0	0	0	0
N10:50	3	5	-15	950	960					

AMCI

ADVANCED MICRO CONTROLS INC.

PLYMOUTH INDUSTRIAL PARK, TERRYVILLE, CT 06786 T: (860) 585-1254 F: (860) 584-1973

LEADERS IN ADVANCED CONTROL PRODUCTS